

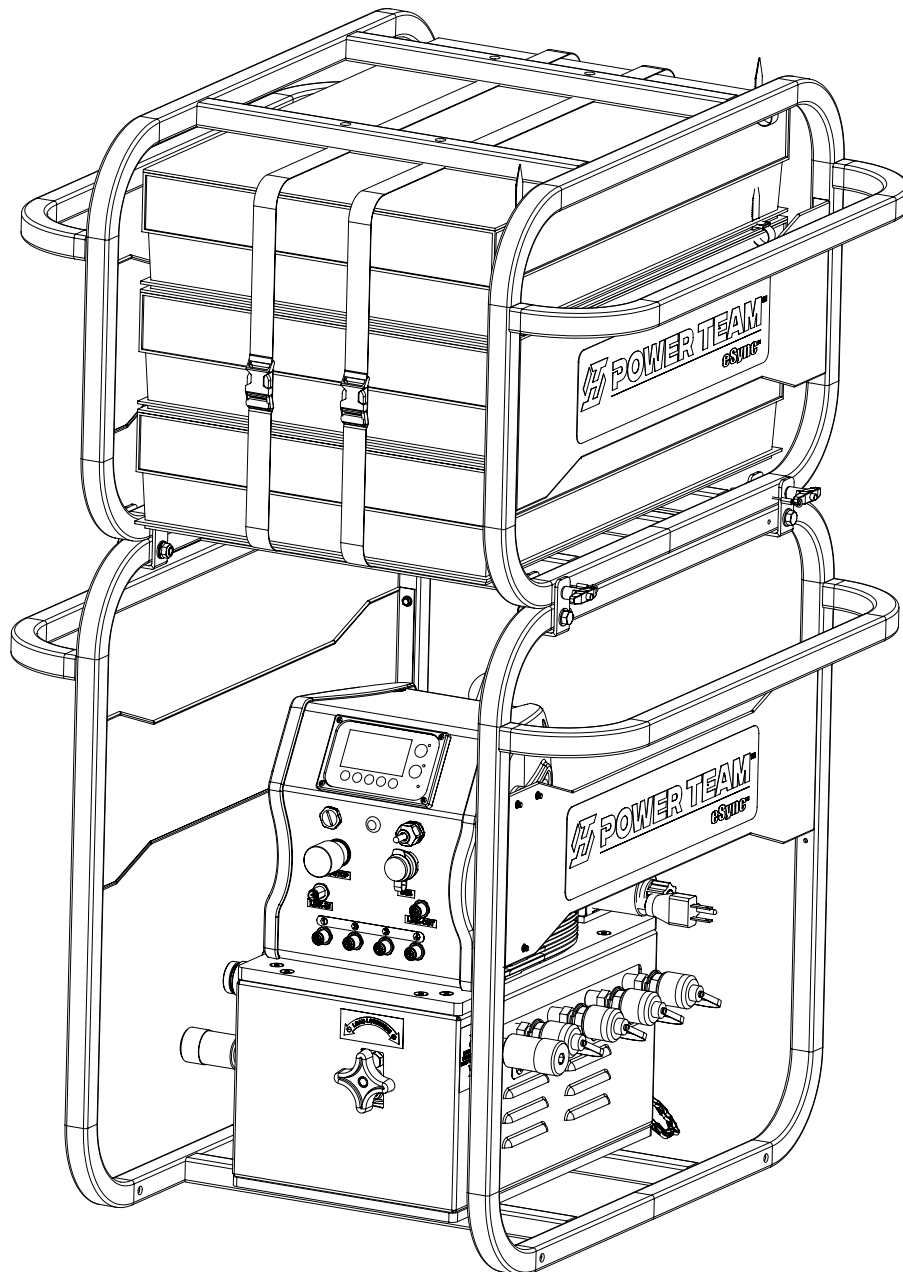

eSync

PORTABLE HYDRAULIC SYNCHRONIZED MOTION CONTROL SYSTEM



Model shown for ES14PRTXA

TABLE OF CONTENTS

GLOSSARY	3
DESCRIPTION	5
SAFETY SYMBOLS AND DEFINITIONS	6
SAFETY PRECAUTIONS	6
COMPONENT IDENTIFICATION	12
1. eSync Unit	12
2. Control Panel.....	14
3. Hand Pendant Control	14
ESYNC SET-UP INSTRUCTIONS	15
1. Before First Use	15
2. Hydraulic Connections	15
3. Hydraulic Cylinder Position	16
4. Displacement Sensor Installation	17
5. Connecting Multiple eSync Units	19
6. Connecting eSync Unit (Corded) to Electric Outlet	20
7. Inserting Battery Pack into the eSync Unit (Cordless)	21
PUMP SET-UP INSTRUCTIONS	22
1. Before First Use	22
2. Filling the Pump Reservoir	22
3. Connecting Electric Pump to the eSync Unit (Corded)	23
4. Connecting Battery Pump to the eSync Unit (Cordless)	24
5. Bleeding Air from the System	27
LCD SCREEN FUNCTIONS	28
1. LCD Operational Buttons	28
2. LCD Startup Splash Screen	29
3. Output Screen Overview	30
4. Main Menu Options	31
ESYNC OPERATION	43
1. Before Operation	43
2. Hand Pendant Operation.....	43
3. Manual Operation	44
4. Auto Operation	46
5. Load Lowering Valve Operation.....	47
PUMP OPERATION	48
1. Before Operation	48
2. Priming the Pump	48
3. Electric Pump (PE60) Operation	48
4. Battery Pump (PB43) Operation	49
5. Adjusting the Pressure Regulating Valve	49

TABLE OF CONTENTS

GENERAL MAINTENANCE	50
1. System Evaluation	50
2. Inspection	50
3. Periodic Cleaning	50
4. Hydraulic Fluid Level	50
5. Draining and Flushing the Reservoir	51
6. Adding Hydraulic Fluid to the Reservoir	51
7. Hose Connections	51
8. Storage	52
9. Checking Brushes on Universal Motors	52
LCD FAULT MODE GUIDE	53
TROUBLESHOOTING GUIDE	55
1. For eSync System	55
2. For Pump Unit	57
3. For Battery Pack and Charger	60
HYDRAULIC SCHEMATIC	61
1. For Double Acting Cylinders	61
2. For Single Acting Cylinders	62
COMPONENT SPECIFIC DATA SHEET	63
POWER TEAM FACILITIES AND CONTACT	64
EC DECLARATION OF CONFORMITY	65

GLOSSARY

In the context of this Instruction sheet, the following words have the meaning as described:

Accuracy	Difference in measurement unit (mm or inch) between the load movement of the leading vs the lagging lifting point.
Actuation Time	Time period during which the spool of the directional valve as well as the spool of a 2-position-2-way valve to at least one hydraulic circuit is energized.
Auto Mode	Operational mode in which the micro unit determines the actuation time of each 2-position-2-way valve and thus keeps the movement of the load within the preset accuracy.
Displacement Sensor	Device to measure the movement of the load as a result of the application of forces generated by hydraulic cylinders.
Relative Zero	The starting point of the controlled load movement is achieved by selecting the "Relative Zero" function on the LCD panel.
Absolute Zero	Used when position sensors are attached to the cylinder and not the object. Set the cylinder base point by selecting the "Absolute Zero" function on the LCD panel. Absolute Zero function is accurate (showing full stroke of cylinder) only when position sensors are attached to the cylinder body, cap, or ram and zero is set when cylinder is fully retracted.
Hydraulic Circuit	Hydraulic Cylinder is connected to a 2-way-2-position valve and the return line of the pump unit via a hydraulic hose.
Lifting Point	The location on the load where force generated by hydraulic cylinders is applied.
Manual Mode	The operator is solely responsible and in control of the movement of each cylinder while using manual mode!
 WARNING	Operational mode in which the micro unit does NOT have any automated control function.
Measuring System	Set of displacement sensor, sensor cable and pressure transducer.
Motion Control	Any type of movement or translocation of a heavy load by means of forces generated by hydraulic cylinders operated by and under the control of a micro based control system.
Micro Unit	Micro unit is a small electronic device composed of analog input channels, digital output channels and computing capabilities to control the advance and retract operation of hydraulic cylinders within specific parameters of accuracy and repeatability.

Glossary Continued

Pressure Sensor	Device to measure the oil-pressure within the hydraulic circuit.
Pump Unit	Assembly of a hydraulic pump mounted on a reservoir with valves and pressure sensors.
Sensor Cable	Shielded cable between the Displacement sensor and the micro unit as carrier for the analog signal generated by the Displacement sensor.
Target	Total movement of the load that shall be achieved simultaneously at all lifting points under the control of the micro unit.
E-Stop	Emergency E-Stop button severs power to the eSync and pump that's plugged into the eSync either by AC plug or tether plug on the Cordless/Battery version.
USB	USB flash drive is used for the storage of data and transfer of computer files. Device used to store the data log of the lifting project. Only auto/synchronous operations are recorded, no manual operations. Function must be turned on and not exceeding the allotted capacity from the user input parameters.

DESCRIPTION

The Power Team eSync lifting system is a standalone motion control system featuring four lift points and operates based on micro control unit technology. The system includes a LINK SETUP feature, enabling users to manage up to 64 lift points by connecting multiple eSync units via the Link-In and Link-Out communication capabilities. Unit is specifically designed for precise control of lifting, lowering, and pushing heavy loads using multiple synchronized hydraulic cylinders.

The eSync is offered in multiple corded or cordless configurations. One is provided with a power cord for direct connection to an electrical outlet. On the other hand, the cordless configuration utilizes a rechargeable battery and charger source that are included with the unit.

The unit is specifically designed to function smoothly with Power Team pump units, which come in electric and battery-powered options. These pump units supply the essential 700 bar (10,000 psi) of hydraulic fluid needed for the efficient operation of the eSync system. It is strongly advised to exclusively utilize Power Team pumps as the primary source for the eSync units. Using alternative pump units may compromise the performance and safety of the system.

This control system allows manual control of individual cylinders for setup requirements and automatically controls directional valves in auto mode to keep the load level within a specific tolerance, capable of maintaining this tolerance across all cylinders as low as 1 mm, depending on pump volume output in relation to cylinder size. The system can be adjusted using user inputs for valve timing for minor discrepancies in pump output or variations in cylinder size.

The LCD screen displays monitoring of lifting points, user menus, and comprehensive safety features are fitted as standard. One hydraulic setup suits both single and double-acting cylinders under different pressures and loads in each circuit.

A synchronized lifting system is typically used for applications such as bridge lifting or repositioning, lifting and lowering of heavy equipment, leveling of structures, and structural testing.

NOTE: When using single-acting cylinders, an over-center or other appropriate valve should be used as safety in the event of a hose break.

Complete eSync unit package consists of the following modules

- Control System
- Measuring System
- Valve System
- Electric/Electronics
- Battery and Charger (Based on configuration)
- Pump Units (Optional)

NOTE: Carefully inspect the unit upon arrival. The carrier, not the manufacturer, is responsible for any damage resulting from shipment. Notify the courier immediately if shipping damage is found and refrain from putting the product into service. The carrier is responsible for repair and replacement costs resulting from damage that occurred in transit.

NOTE: The images used throughout this manual are for illustrative purposes ONLY. They are intended to enhance the understanding of the content and provide visual examples. The images may not necessarily represent the exact product or situation being described. Please refer to the accompanying text for accurate information and instructions.

IMPORTANT: For instructions specific to the various system components refer to the related individual instructions sheets that have been included with the eSync.

SAFETY SYMBOLS AND DEFINITIONS

Safety symbols are used to identify any action or lack of action that can cause personal injury. Your reading and understanding of these safety symbols is very important.

 **DANGER**: Indicates an imminently hazardous situation which, if not avoided, will result in death or serious injury.

 **WARNING**: Indicates a potentially hazardous situation which, if not avoided, could result in death or serious injury.

 **CAUTION**: Indicates a potentially hazardous situation which, if not avoided, may result in minor or moderate injury.

CAUTION: Used without the safety alert symbol indicates a potentially hazardous situation which, if not avoided, may result in property damage.

IMPORTANT: Important is used when action or lack of action can cause equipment failure, either immediate or over a long period of time.

SAFETY PRECAUTIONS

These instructions are intended for end-user application needs. For a detailed parts list or to locate a Power Team Authorized Hydraulic Service Center contact your nearest Power Team facility. A list of all Power Team facilities is located at the end of this document.

 **WARNING**: To help prevent personal injury,

General Safety



- The following procedures must be performed by qualified, trained personnel who are familiar with this equipment. Operators must read and understand all safety precautions and operating instructions included with this unit. If the operator cannot read these instructions, operating instructions and safety precautions must be read and discussed in the operator's native language. For the latest version of the instructions, please visit our website at www.hydraulictechnologies.com.
- These components are designed for general use in normal environments. These components are not specifically designed for lifting and moving people, agri-food machinery, certain types of mobile machinery or special work environments such as: explosive, flammable, or corrosive. Only the user can decide the suitability of this machinery in these conditions or extreme environments. The Power Team will supply information necessary to help make these decisions. Consult your nearest Power Team facility.



- Safety glasses must be worn at all times by the operator and anyone within sight of the unit. Additional personal protection equipment may include: face shield, goggles, gloves, apron, hard hat, safety shoes, and hearing protection.
- Operation, repair, or maintenance of hydraulic equipment should be performed by a qualified person who understands the proper function of hydraulic equipment per local directives and standards.
- Hydraulic equipment must be assembled correctly and then checked for proper function before use. Use hydraulic components of the same hydraulic pressure ratings. An appropriate hydraulic pressure gauge is recommended to monitor pressure.
- Never place your hands or other body parts near a hydraulic fluid leak. Never use your hands or other body parts to check for a possible leak. High pressure fluid can be injected under your skin causing serious injury and/or infection.

Safety Precautions Continued



- High pressure fluid is present throughout a hydraulic system. Always use caution when operating, repairing, or maintaining this equipment. Before beginning any work on any hydraulic system component, stop the equipment, disconnect from its power source, and relieve all pressure in all parts of the system. Do not tamper with the internal hydraulic relief valve settings.



- Avoid exposing hydraulic equipment (especially hoses) to extreme high or low temperatures. Damage to equipment or failure may result and cause loss of control or injury to the operator.
- Exercise caution to avoid the risk of fire.
- Do not drop any hydraulic system components. Damage to the equipment and/or injury may result.



- Keep a safe distance from the lifted load while it is in motion. Do not stand directly underneath or near the load to avoid the risk of being struck or crushed in case of any mishaps.
- The owner of this motion control system must ensure that safety-related decals are installed, maintained, and replaced if they become difficult to read or understand.

Synchronous Lifting System (eSync unit)

CAUTION

: To prevent operator error, perform all of the following steps to develop a lift plan for the requirements, including and especially concentrating on the controlled movement with an assistant operator whose sole task it is to double-check and verify any input and operational action taken by the main operator.

IMPORTANT: All movements to be performed by the eSync unit must be approved by the person responsible at the job site. If on a job site, Power Team employees may answer questions about the function or operation of the eSync unit, but cannot be responsible for static or strength calculations of the structure or load to be moved, or the actual operation of the eSync unit during the lift.

WARNING

: Failure to observe and comply with the following precautions could result in death or serious personal injury. Property damage could also occur.

- It is the responsibility of the user of this equipment to create a lifting plan in accordance with their company's policies. That plan should include at least the following items:
 - » Who is involved and what their responsibilities are?
 - » What are the lift objectives, and what are the actions and their sequence in order to achieve the lift?
 - » When will the lift take place, over what time frame?
 - » Where the lift takes place and where critical lift or reaction points are located.
 - » A comprehensive safety plan.
 - » Local special conditions (legal, environmental, geographical, etc.)

Before putting the eSync unit into operation, the operator shall analyze the lift application for all foreseeable risks, their likelihood to occur, and the potential consequences of the identified risks as per ISO 31000 and ISO/IEC 31010 in their actual current version.

- After setting up the eSync unit, the system needs to be tested for correct mapping of circuit number on the screen versus displacement sensors and correlation with the 2-way valves. Extend each displacement sensor individually for approximately 100 mm and verify the displacement indication on the screen to show the same change of values. Set the system into "Manual" mode and activate each circuit one by one. Verify the function of the related 2-way valve by checking the movement of the spool core.

Safety Precautions Continued

Pump Unit

WARNING

- It is recommended to use Power Team pumps as the primary source for the eSync units. Using alternative pump units may compromise the performance and safety of the system.
- Do not exceed the hydraulic pressure rating noted on the pump nameplate or tamper with the internal high-pressure relief valve. Creating pressure beyond rated capacities can result in personal injury.
- Before replenishing the fluid level, retract the system to prevent overfilling the pump reservoir. An overfill can cause personal injury due to the excess reservoir pressure created when the tools are retracted.
- Before performing maintenance or repairs, ensure that the pump is disconnected from the power source, or if battery-operated, remove the battery from the pump unit and release any built-up pressure.
- Do not connect a pump to a hydraulic system powered by another pump.
- Never remove or modify the pump's safety devices.

Electric Driven Motor

WARNING



- Any electrical work must be done and tested by a qualified electrician per local directives and standards.
- Disconnect the pump from the power supply and relieve pressure before removing the motor case cover or performing maintenance or repair.
- Never use an ungrounded power supply with this unit.
- If the power cord is damaged or wiring is exposed, replace or repair immediately.
- Changing the voltage on this unit is an involved, and if improperly performed, hazardous procedure. Consult the manufacturer for specific information before attempting any rewiring.
- Pump motors must be wired for clockwise (CW) rotation when viewed from the lead end (top) of the motor.
- Check the total amperage draw for the electrical circuit you will be using. (For example: Do not plug a pump or pumps that may draw 25 amps into a 20 amp fused electrical circuit.)
- Do not attempt to increase the current capacity by replacing a fuse with another fuse of higher value. Overheating and the possibility of a fire could result.
- Electric pumps should never be exposed to rain or water which could cause personal electrical hazard.
- Avoid conditions which can cause damage to the power cord such as abrasion, crushing, sharp cutting edges, or corrosive environment. Damage to the power cord can cause an electrical hazard.

Safety Precautions Continued

Battery and Battery Charger

CAUTION: To reduce risk of injury, charge Power Team batteries only with Power Team battery chargers. Other battery packs may rupture, resulting in physical injury and property damage.

⚠ WARNING



- Ensure rechargeable battery contacts cannot be shorted by metal objects, such as screws, instruments or nails. A short circuit between the battery contacts can cause burns or fire.



- Do not burn the charger or rechargeable batteries. Rechargeable batteries may explode and flare up.
- As a result of improper use, liquid can leak from the battery. Avoid contact with this liquid. If battery liquid leaks and contact occurs, flush with water and seek medical help.



- Store battery and battery charger in a cool, dry place. Keep these items in a secured area, away from children and pets. Unplug battery charger when cleaning or not in use.

- Do not allow children to use or play with the battery pack or battery charger; local regulations may restrict the age of the operator.



- Do not discard batteries into domestic waste disposal. Any damaged or disposed electric or electronic devices must be delivered to appropriate collection centers.

- For indoor usage only. Do not use the charger outside or expose it to wet or damp circumstances when charging the battery. Water entering the charger increases the chance of an electric shock.

⚠ CAUTION

- If the battery is stored without being charged, natural drainage will cause the power to be reduced. The battery should be completely re-charged every three months if not in use.
- Only use the battery and charger that is supplied by manufacturer. Using a different battery or different charger may cause an explosion.
- If the supply cord to the battery charger is damaged, contact an Authorized Service Dealer to replace it.
- Do not use a battery pack or charger that is damaged or modified. Damaged or modified batteries may show unpredictable behavior resulting in fire explosion or risk of injury.
- Allow battery to cool completely before charging.
- Do not disassemble or attempt to repair the battery or battery charger.

Hydraulic Hoses and Fluid Transmission Lines

⚠ WARNING

- Before operating the pump, tighten all hose connections using the correct tools. Do not over-tighten. Connections should be secure and leak-free. Over-tightening can cause premature thread failure or high pressure fittings to split at pressures lower than their rated maximum operating pressure.



- Should a hydraulic hose rupture, burst, or need to be disconnected, immediately depress the **RED** emergency E-Stop Button to shut off the complete eSync unit. Never attempt to grasp a leaking hose under pressure with your hands. The force of escaping hydraulic fluid could cause serious injury.



- Do not subject the hose to potential hazards such as fire, sharp surfaces, heavy impact, or extreme heat or cold. Do not allow the hose to kink, twist, curl, or bend so tightly that the fluid flow within the hose is blocked or reduced. Periodically inspect the hose for wear, because any of these conditions can damage the hose and possibly result in personal injury.

Safety Precautions Continued

- Do not leave a hydraulic hose in a position where it could shift under a raised load in order to prevent the hose from being crushed or ruptured when the load is lowered.
- Do not use the hose to move attached equipment. Stress can damage the hose and possibly cause personal injury.
- Hose material and coupler seals must be compatible with the hydraulic fluid used. Hoses also must not come in contact with corrosive material such as creosote-impregnated objects and some paints. Consult the manufacturer before painting a hose. Never paint the couplers. Hose deterioration due to corrosive materials may result in personal injury.

Cylinder

DANGER

- Do not exceed rated capacities of the cylinders. Excess pressure may result in personal injury.
- Never use extreme heat to disassemble a hydraulic cylinder or ram. Metal fatigue and/or seal damage will result and can lead to unsafe operating conditions.
- To help prevent personal injury, do not allow personnel to go under or work on a load before it is properly cribbed or blocked. All personnel must be clear of the load before and during lowering.
- Because this system is used to lift or lower loads, be certain that the load is under operator control at all times and that others are clear of the load.



WARNING

- Read and understand all safety and warning decals and instructions for devices attached.
- Avoid off-center loads that could damage the cylinder and/or cause loss of the load.
- Cylinders should be arranged, as much as practical, to evenly distribute the load to each cylinder.
- Inspect each cylinder and coupler before each shift or usage to prevent unsafe conditions from developing.
- Do not use cylinders if they are damaged, altered or in poor condition.
- Do not use cylinders with bent or damaged couplers or damaged port threads.
- With the eSync, the use of an extension with a hydraulic cylinder is prohibited.
- Avoid pinch points or crush points that can be created by the load or parts of the cylinder.
- To help prevent material fatigue if the cylinder is to be used in a continuous application, the load should not exceed 80% of the rated capacity or stroke.
- Cylinder must be on a stable base which is able to support the load while pushing or lifting.
- To help prevent personal injury, use shims, friction material or constraints to prevent slippage of the base or load.
- Do not set poorly-balanced or off-center loads on a cylinder. The load can tip or the cylinder can “kick out” and cause personal injury.
- Do not use the locking collar on a threaded piston as a stop. The threads may shear resulting in loss of the load, damage to equipment and personal injury.
- Never rapidly drop the load in an uncontrolled manner.
- As the load is lifted, use mechanical blocking and cribbing to guard against a falling load.



Safety Precautions Continued

IMPORTANT:

- Keep the cylinders clean at all times.
- While at a job site, when the cylinder is not in use, keep it fully retracted and upside down.
- Use an approved, high-grade pipe thread sealant to seal all hydraulic connections. PTFE tape can be used if only one layer of tape is used and it is applied carefully (two threads back) to prevent the tape from being pinched by the coupler and broken off inside the pipe end. Any loose pieces of tape could travel through the system and obstruct the flow of fluid or cause jamming of precision-fit parts.
- Always use protective covers on disconnected quick couplers.
- Limiting the stroke on spring return cylinders will prolong spring life.
- Limiting the stroke and pressure on all cylinders will prolong their life.

⚠ DANGER : A double-acting cylinder or ram must have both hoses and all couplers securely connected to both ports. If one of the two ports is restricted or becomes disconnected, pressure will build and the cylinder, hose or coupler can burst, possibly causing serious injury or death.

Control Panel



- If the LCD screen becomes unreadable at any time during operation of the eSync unit, depress the **RED** emergency stop button **IMMEDIATELY** to stop system operation until trouble shooting of malfunction can be performed.
- Disconnect the electrical control panel from the power supply before opening or removing the cover of the control unit or performing maintenance or repair on electrical components.
- Some electronic components inside the electrical control unit are sensitive to static charges. Always use an anti-static wrist band connected to the ground-earth bar inside the electrical control unit before performing any maintenance or repair work on those electronic components.

Hydraulic Fluids

- Properly dispose of all fluids, components and assemblies at the end of their useful lives according to the applicable local waste treatment and environmental regulations.
- Hydraulic fluid should be compatible with all hydraulic components.

Transport



- Do not lift eSync unit or hydraulic pump by any electrical cord, hose or coupler. To safely transport, always use the carrying handle, roll cage or suitable lifting aid, along with assistance and proper lifting techniques.

Fuse

⚠ WARNING : If motor stops due to an overload or power outage:

- Press **STOP** button and shift valves to neutral position. Unplug or disconnect power supply and allow motor to cool. Check in-line fuse before reconnecting unit to power supply.

Note: The guide cannot cover every hazard or situation so always do the job with **SAFETY FIRST**.

COMPONENT IDENTIFICATION

The components shown below are for both versions of the eSync: one that operates using a power cord (corded) and another that operates using a rechargeable battery (cordless).

1. eSync Unit (Corded and Cordless)

- A. Roll Cage / Frame
- B. Retract Ports Line
- C. Retract Pressure Relief Valve
- D. Pump Unit (Optional)
- E. Load Lowering Valve
- F. Advance Pressure Relief Valve
- G. Advance Ports Line
- H. Three Storage boxes/Totes

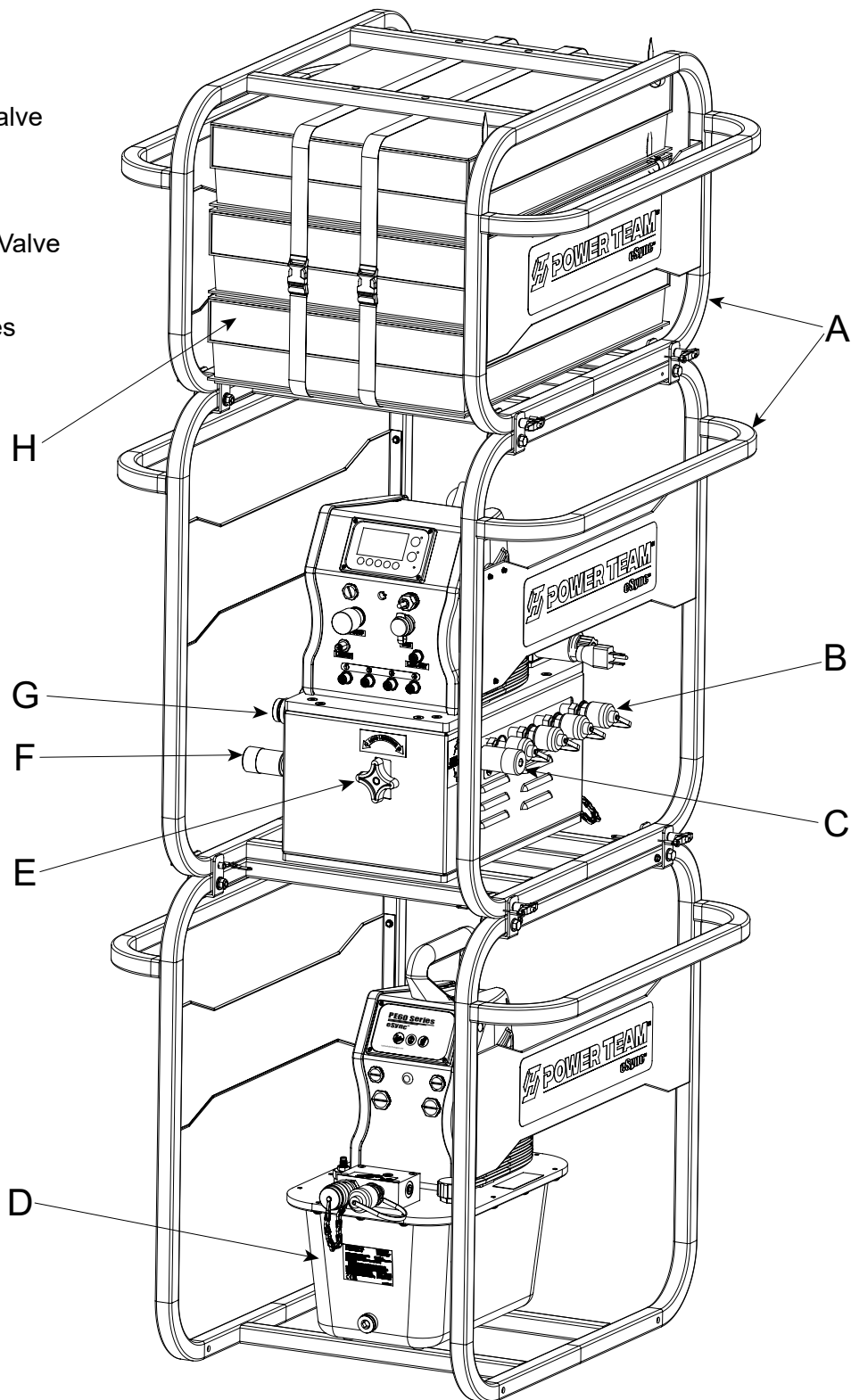

Fig. 1: eSync Unit Front View

Component Identification Continued

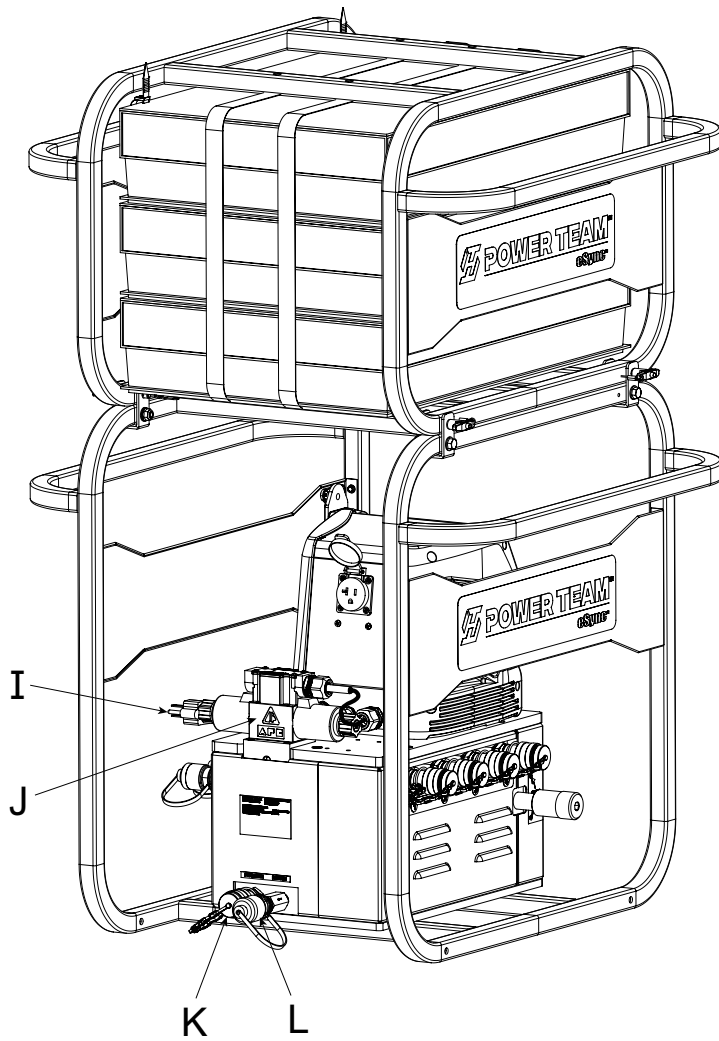
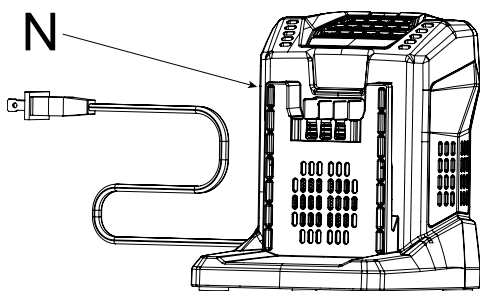

Fig. 2: eSync Unit Rear View (Corded)

M. Battery Pack

N. Battery Charger (US/EU version)



- I. Power Cord (Corded Pump)
- J. Solenoid Distribution Valve
- K. Pressure Port
- L. Return Port

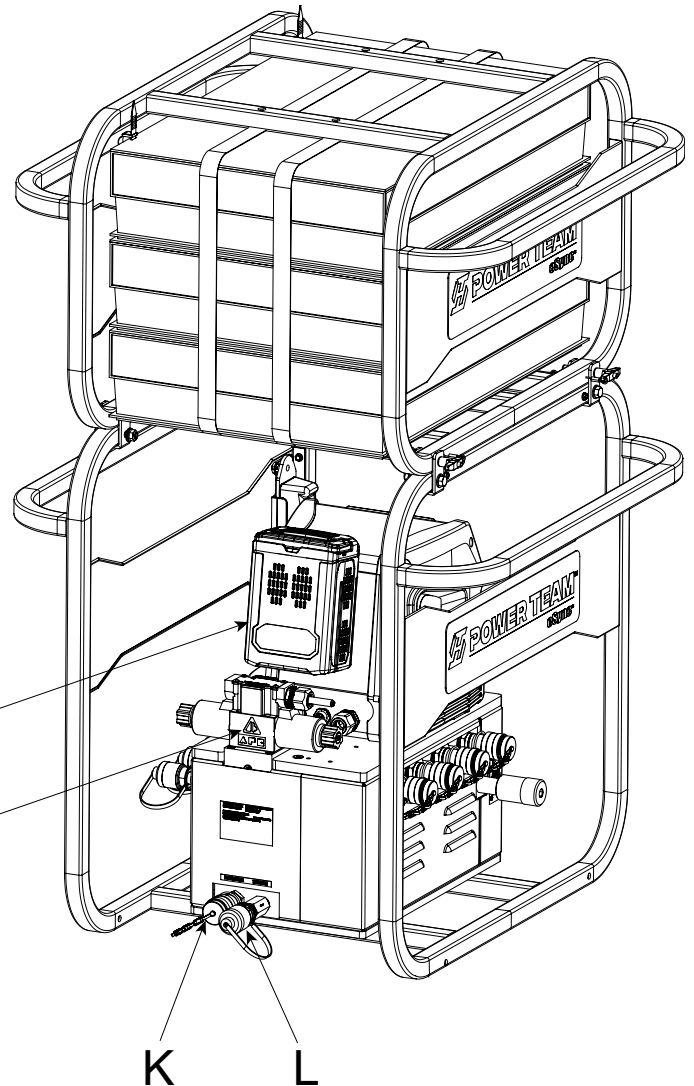

Fig. 3: eSync Unit Rear View (Cordless)

Component Identification Continued

2. Control Panel

- A. LCD Screen
- B. E-Stop
- C. Link-In
- D. Displacement Sensor Cable Connections
- E. Hand Pendant Connection
- F. USB
- G. Link-Out

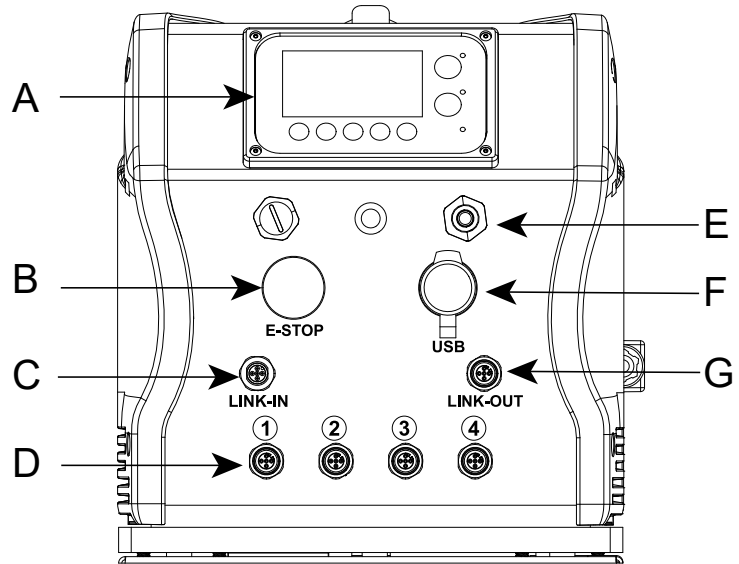

Fig. 4: Control Panel

3. Hand Pendant Control

- A. Auto Stop Button
- B. Manual / Auto Switch Button
- C. Advance Button
- D. Retract Button

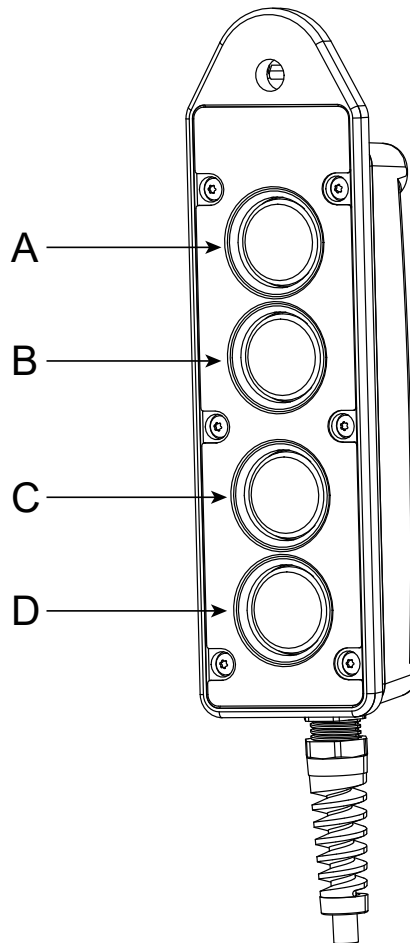

Fig. 5: Hand Pendant Control

ESYNC SET-UP INSTRUCTIONS

1. Before First Use

- Start by inspecting the eSync unit, cables, sensors, cylinders, and connectors (both electrical and hydraulic) to make sure all components are intact and free from visible damage.
- Make sure that all components such as hoses, couplers, and cylinders are rated for the maximum operating pressure provided by the pump unit 700 bar (10,000 PSI). Do not mix high and low pressure components.

⚠ WARNING : It is recommended to use Power Team Pumps and Vales that supports fluid supply system for the eSync unit. If you prefer to use a different pumps or fluid supply system, please reach out to Power Team technical support for appropriate guidance.

- When using Power Team pumps for fluid delivery, make sure to pair the electric version pump exclusively with the electric eSync unit, and the battery pump solely with the battery-powered eSync unit.

2. Hydraulic Connections

- A. Use the clean cloth or rag to wipe away any visible dirt, debris, or residue from the areas around the fluid ports, hose ends, couplers, or union ends. Be gentle to avoid damaging any components.
- B. Remove the thread protectors from the hydraulic fluid outlets. Inspect all threads and fittings for signs of wear or damage, replace as needed.
- C. Hose connection between eSync and pump unit: Identify the inlet (return) and outlet (pressure) ports on the hydraulic pump. Connect one end of the hydraulic hose to the outlet port of the pump and the other end to the pressure port of the eSync unit (shown in figure 6), ensuring a tight and secure fit. Repeat this step for the inlet port of the pump to connect to the return port.
- D. Hose connection between eSync unit and cylinders: Identify the inlet and outlet ports on each hydraulic cylinder. Connect one end of the hydraulic hose to the inlet port of each cylinder and the other end to each end of the lift point hydraulic outlet (advance ports), ensuring a tight and secure fit. Repeat this step for the outlet port of each cylinder to connect to the retract ports.
- E. Adjust the Advance and Retract Pressure Relief Valves settings to the desired pressure setting. Turning clockwise will raise the pressure level, while turning counterclockwise will lower it.
- F. Once all connections are made, visually inspect the connections and fittings for any signs of leakage. If any leaks are detected, tighten the fittings further or replace any damaged components.

⚠ CAUTION : To prevent personal injury from leaking hydraulic fluid, seal all hydraulic connections with a high-quality, non-hardening, pipe thread sealant.



IMPORTANT: Sealant tape or non-hardening sealer tape can be used to seal hydraulic connections if only one layer of tape is used. Apply tape carefully, two threads back, to prevent it from being pinched by the coupler and broken off inside the system. Loose pieces of sealant could travel through the system and obstruct the flow of fluid or cause jamming of precision-fit parts.

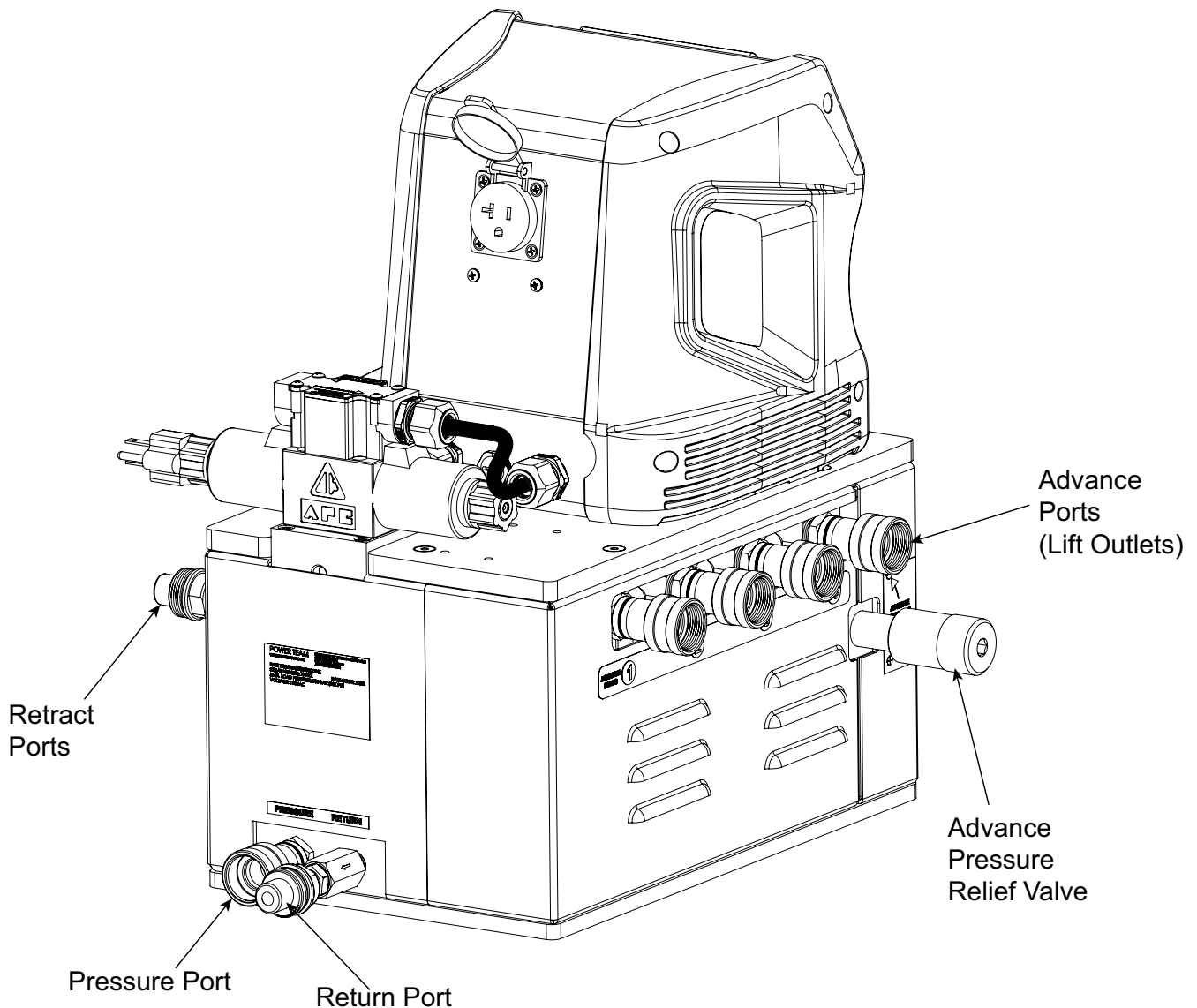

Fig. 6: eSync Unit Hydraulic Connections

3. Hydraulic Cylinder Position

IMPORTANT: When placing the cylinders under the load to be lifted, the cylinders should be placed on a surface that is capable of supporting a minimum of 1.5 times the rated cylinder capacity without surface deformation. For example, use properly sized load-distributing steel plates in order to remain below maximum local surface loading conditions. Failure to do so may result in surface deformation that may lead to an unsuccessful lift, personal injury and/or damage to the structure being lifted.

- In addition to ground level surface support, make sure that the support point on the load to be lifted is capable of withstanding and distributing the lifting forces without deformation to the lift point itself.
- A review of each lift point's estimated load should be performed, so that when selecting and sizing cylinders for the lift, it is recommended that the load on the cylinder at each lifting point should not exceed 80% of the rated cylinder capacity.

eSync Set-Up Instructions Continued

4. Displacement Sensor Installation

The linear displacement sensors included with the eSync unit are used to determine the relative position of each sensor with respect to all other linear sensors, with the eSync providing incremental adjustments to keep all cylinders within a predetermined range. The sensors are assembled to magnetic bases that allow each sensor to be attached to the load being lifted close to the cylinder that sensor represents. The sensors should be mounted as close as practical to each lift cylinder used in the lifting process.

The displacement sensor must be firmly mounted as close as practical to the lift cylinder in a position that allows free cable movement and where damage to the sensor or cable from foreign objects is unlikely. The sensor will operate in any orientation. Where cable contamination by oil, water, or particulate matter is possible, the sensor should be mounted in the vertical plane with the sensor wire cable pointing down. Where necessary, a sensor shield should be incorporated in the mounting assembly to protect the sensor from falling solids or liquid media. It is also good practice to mount the sensor onto or close by a rigid part of the machine or system.

When mounting the position sensor, make sure the linear travel of the sensor wire cable extends straight from the sensor with minimal degree deviation when extended. If the wire has an extensive angle from the sensor, this would cause incorrect positioning of the load during lifting or lowering.

- A. Attach the displacement sensors close to each lifting point. Preferably with the displacement sensors magnet base right side down (shown in figure 7). If hanging upside down on the load the sensor could come loose and damage the sensor if dropped.
- B. Connect each displacement sensor to the corresponding port on the eSync unit using sensor signal cables. To connect each sensor signal, align the male and female connectors for the correct orientation and press together. Turn the collar(s) on the cable connector(s) clockwise to fully engage the connector(s) and secure the cable connection(s).
- C. Once all sensors and sensor signal cables are properly installed, make sensor connections by gently pulling the sensor wire cable out of the sensor and attaching it to the cylinder foundation. Make sure that the displacement sensor's wire is pulled out several mm with the magnet stud under slight tension in order to set an accurate "zero" point for the relative displacement measurements.

IMPORTANT: Any deviation from the sensor wire coming straight out of the sensor will reduce the life of the cable and may affect the linear position readout, which could result in an unsuccessful lift.

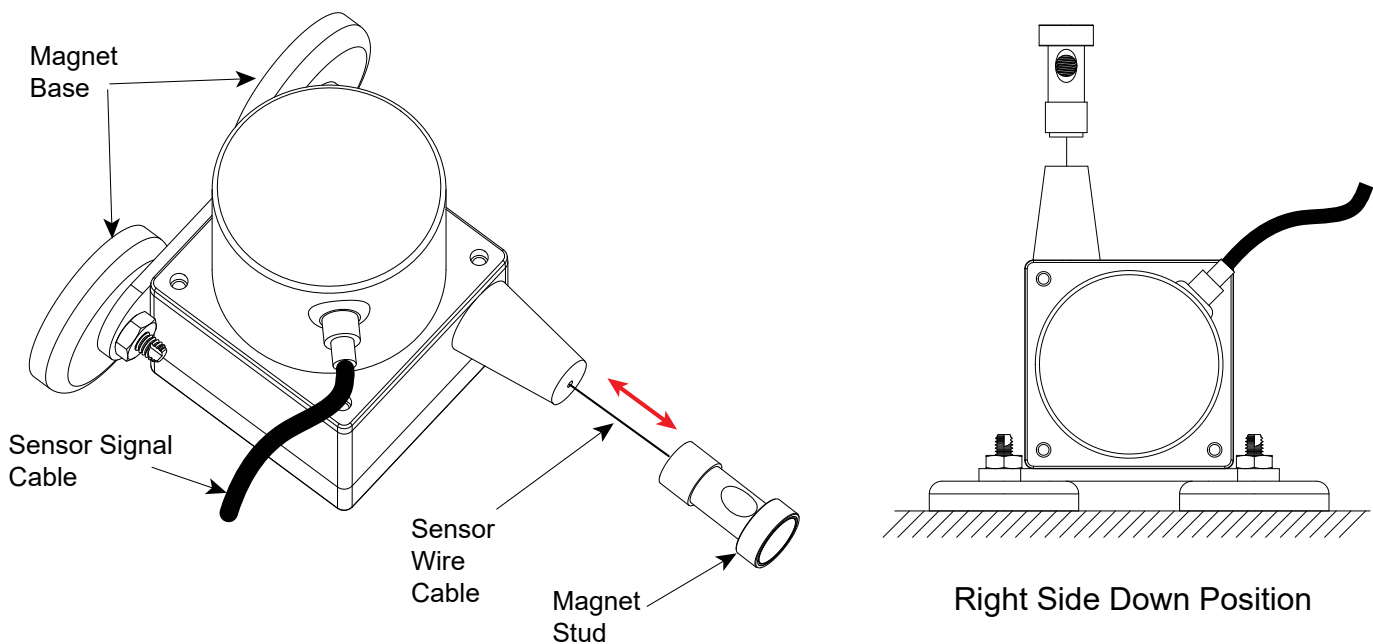

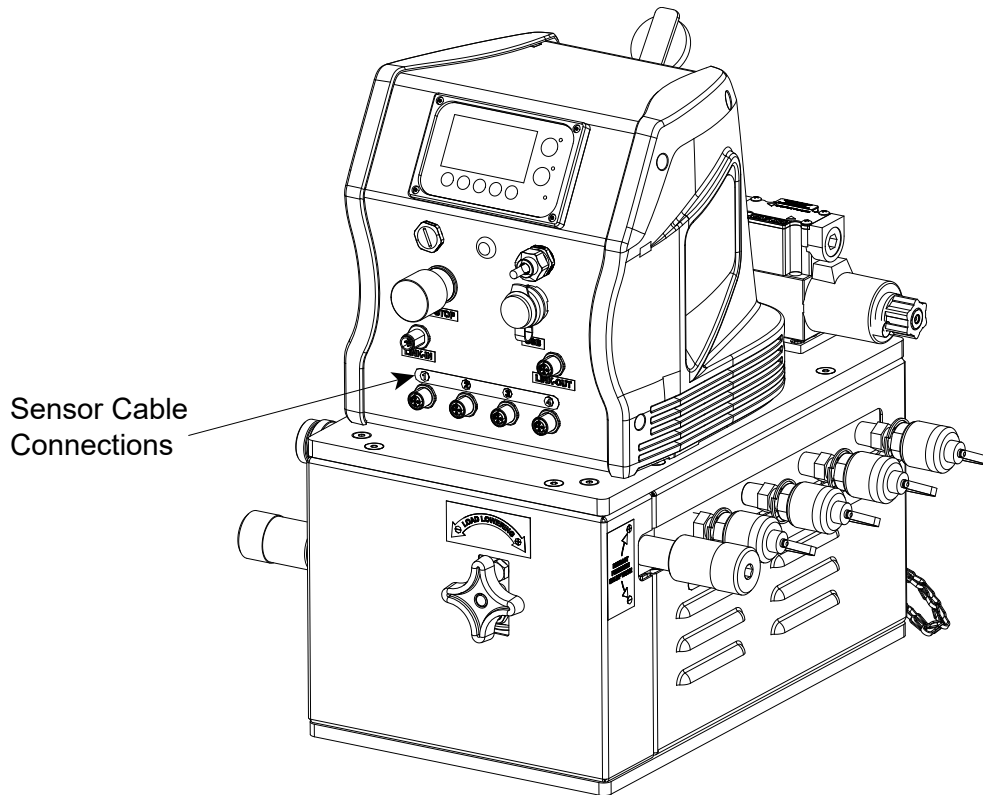

Fig. 7: Displacement Sensor Installation

CAUTION

- **Avoid releasing the sensor retractable wire and letting it freely snap back to its neutral position. This can cause damage to the calibration and functionality of the displacement sensor.**
- **As a regular occurrence, moving heavy loads is typically performed at night with limited visibility. Make sure that each lifting point, especially the location of the electrical control unit and pump unit, has sufficient lighting. As a general rule, always protect the electrical control unit from environmental influences such as rain, dust, vibration, heat, physical damage, etc.**

eSync Set-Up Instructions Continued

5. Connecting Multiple eSync Units

The Link-In and Link-Out functionality enables you to connect a master eSync unit with one or more remote eSync units. This feature allows multiple eSync (4-point) units to function as a single system, facilitating larger multi-point synchronous lifts controlled from a single master unit.

- A. To connect multiple eSync units to the master unit, use a connecting cable with male and female connectors.
- B. Notice the grooves on the female connector and alignment pins on the male connector.
- C. Connect one end of the cable's male connector to the female connector (Link-Out) on one eSync unit, and connect the other end of the cable's female connector to the male connector (Link-In) of the next unit in the sequence (see figure 8).
- D. Secure the connection by threading (rotating clockwise) the cable fitting into the pump unit fitting.
- E. Any unit within the chain can be made as the master unit. For LCD settings, refer to "LINK SETUP" instructions under section "LCD SCREEN FUNCTIONS" for connecting multiple eSync units.
- F. Following LCD settings are controlled by the master unit "SET TARGET", "SET TOLERANCE", "UNITS", and "LOG TIMING" for the linked units.
- G. Individual units control: "ZERO RELATIVE", "ZERO ABSOLUTE", "SET TIMEOUT", "SET VALVE ENABLE", "SET VALVE TIMING", "SET SENSOR MAX", "LCD BACK LIGHT", and "LCD HEATER".

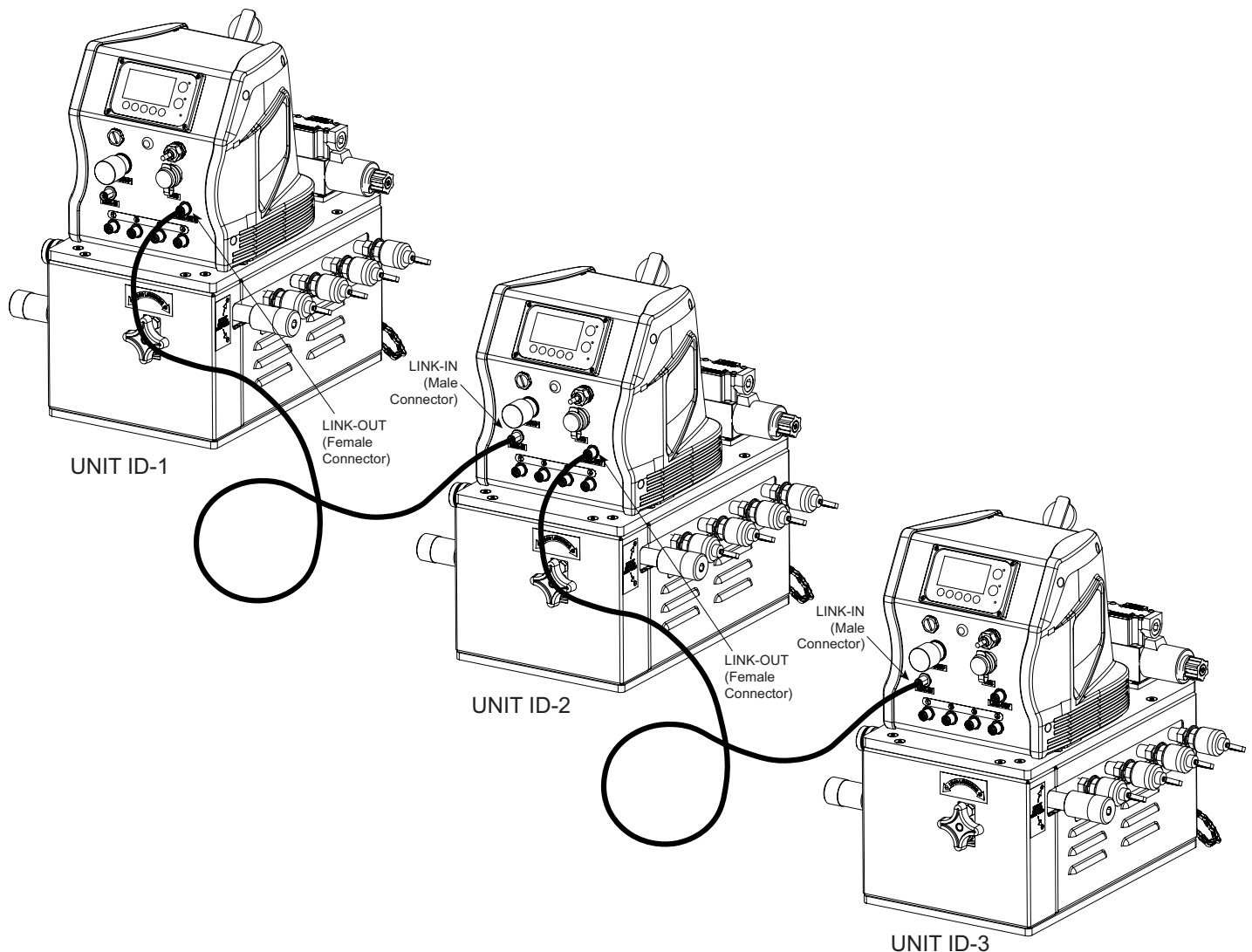

Fig. 8: Multiple eSync Unit Connections

eSync Set-Up Instructions Continued

6. Connecting eSync Unit (Corded) to Electric Outlet

Follow below instructions to setup electric powered eSync unit:

Before establishing an electrical connection, verify the voltage and current specifications for the eSync unit. The eSync unit comes with two distinct power cord configurations: 110VAC, 60Hz and 220VAC, 50/60Hz.

⚠ CAUTION : Electrical power cord plugs /sockets **MUST** match the power source outlet socket. Never modify electrical power plugs or tool/equipment electric.

- A. After all the hydraulic hoses and sensor cables are connected, and the hand pendant is attached, power can be supplied to the eSync unit.
- B. Make sure no buttons on the hand pendant or on the eSync control panel are pressed, and the pump unit switch is in the OFF position.
- C. Locate the power cord of the eSync unit. It should have a plug at the end that matches the electrical outlet you will be using (see figure 9).

NOTE: Ensure that eSync units rated for 110VAC are connected to a 110VAC power outlet. Similarly, connect eSync units rated for 220V only to outlets that support 220VAC. Failure to comply may result in equipment damage or safety hazards.

- D. Inspect the power cord for any damage or frayed wires. If you notice any issues, do not attempt to make the connection and contact a professional for assistance.
- E. Align the prongs of the plug with the corresponding slots in the electrical outlet. Make sure the plug is oriented correctly, with the wider prong (neutral) in the wider slot and the narrower prong (hot) in the narrower slot.
- F. Firmly push the plug into the outlet until it is fully inserted. Ensure that it fits securely and there are no loose connections.

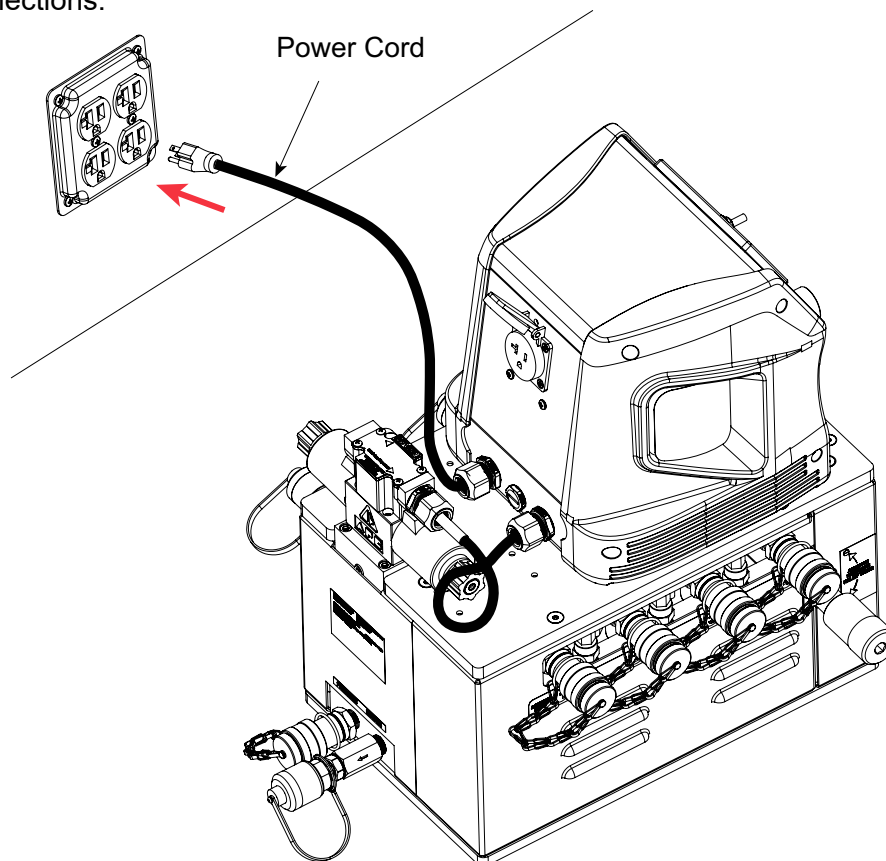

Fig. 9: eSync Electrical Connection

eSync Set-Up Instructions Continued

7. Inserting Battery Pack into the eSync Unit (Cordless)

Follow below instructions to setup battery powered eSync unit:

- After all the hydraulic hoses and sensor cables are connected, and the hand pendant is attached, power can be supplied to the eSync unit.
- Make sure NO buttons on the hand pendant or on the eSync control panel are pressed, and the pump unit switch is in the OFF position.
- Verify the battery capacity level to confirm it is fully charged; if not, charge it before inserting it into the eSync unit.

WARNING: Please adhere to the specified Battery Operating Temperature range of -4°F to 104°F (-20°C to 40°C) and the Battery Charging Temperature range of 41°F to 104°F (5°C to 40°C). Operating or charging the battery outside of these specified temperatures may cause damage to the battery and increase the risk of fire.

- Align the ribs on the battery pack with the battery adapter and gently push the battery pack into the battery adapter until you hear a "click," ensuring it is fully seated and secure (see figure 10).
- Once the battery is properly installed, activate it by pressing the power button on the battery pack and check that it powers on correctly.
- After completing your work, remove the battery from the eSync unit. To remove battery, press the release button on the battery and slide it out.

WARNING: Remove the battery pack from the eSync unit when it is not in use. Leaving the battery installed for an extended period of time can lead to complete drainage, which may cause battery failure and damage the equipment.

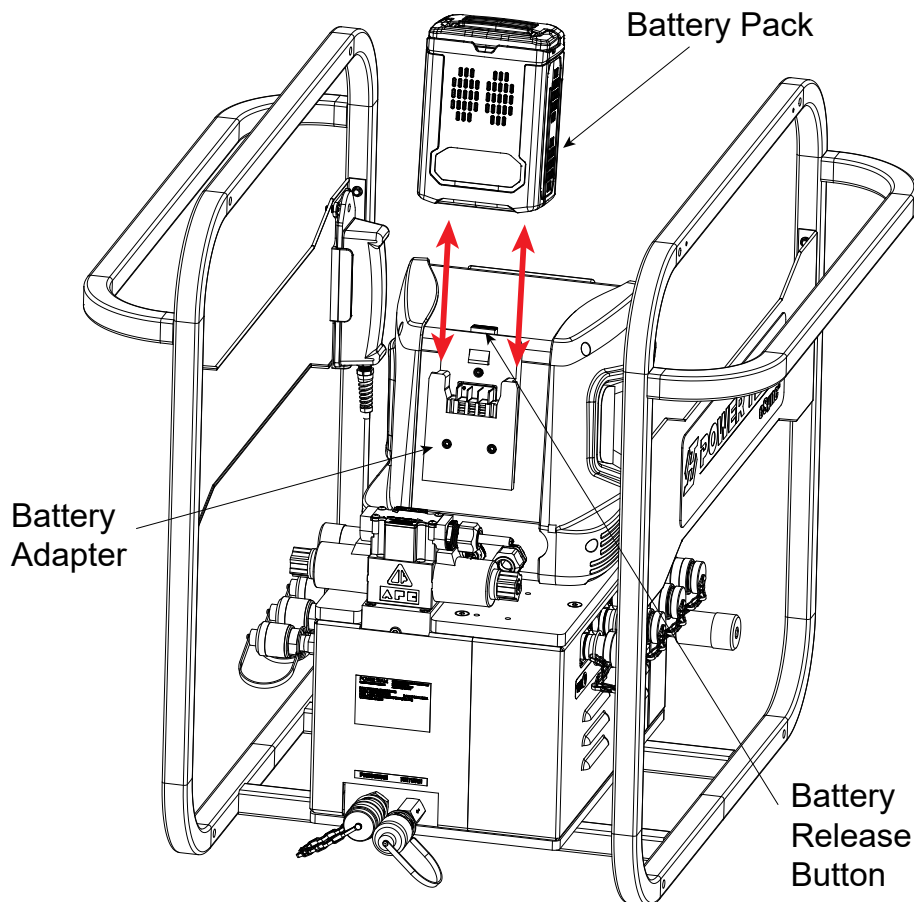

Fig. 10: eSync Battery Pack Installation

PUMP SET-UP INSTRUCTIONS

The following instructions provide the setup guidelines for Power Team electric and battery-powered pump versions with the eSync units.

⚠ WARNING : It is recommended to use Power Team Pumps and Vales that supports fluid supply system for the eSync unit. If you prefer to use a different pumps or fluid supply system, please reach out to Power Team technical support for appropriate guidance.

Power Team currently provides the following pump setup configurations for the eSync unit:

- » **PE60 Electric Version Pump** (115VAC and 230VAC) for the eSync electric version (115VAC and 230VAC)
- » **PB43 Battery Version Pump** (60VDC Battery and 115VAC/230VAC Charger) for the eSync battery version (60VDC Battery and 115VAC/230VAC Charger)

Power Team valve recommendations for the pump unit:

- » **Recommended Valves:** Power Team Valves - 9626 Manifold and 9500 (4Way-3Posi.) valve.
- » **Not Recommended:** Posi-check feature valves.

1. Before First Use

- Begin by visually checking the pump unit, cables, battery, charger and connectors (electrical with cables and hydraulic hoses) to confirm the integrity of all components and that there are no visible signs of damage.
- Make sure that all components such as hoses, couplers, and cylinders are rated for the maximum operating pressure provided by the pump unit 700 bar (10,000 PSI).

2. Filling the Pump Reservoir

NOTE: Most pumps are shipped without hydraulic fluid in the reservoir. Hydraulic fluid may have been shipped in a separate container, but if hydraulic fluid is needed, use only Power Team approved hydraulic fluid rated at 47 cSt @ 38°C (215 SUS @ 100°F). If low temperature requirements are needed, use hydraulic fluid 5.1 cSt @ 100°C (451 cSt @ -40°C).

- A. Clean the area around the filler cap to remove debris. Debris in the hydraulic fluid can damage the polished surfaces and precision-fit components of this pump.
- B. Remove the filler cap and insert a clean funnel with a filter (see figure 11).
- C. Slowly pour the oil into the reservoir, taking care not to overfill it. Check the oil level 1" (25,4 mm) from the bottom of the cover plate or to fill line to ensure it does not exceed the recommended capacity.
- D. After adding oil, securely close the reservoir cap or cover to prevent any leaks or spills. Verify the breather-hole is open, if applicable.
- E. Clean up any oil spillage to avoid causing a safety and/or environmental hazard.

NOTE: Ensure that all connected cylinders are fully retracted before adding oil. This will prevent the system from containing more oil than the reservoir can hold.

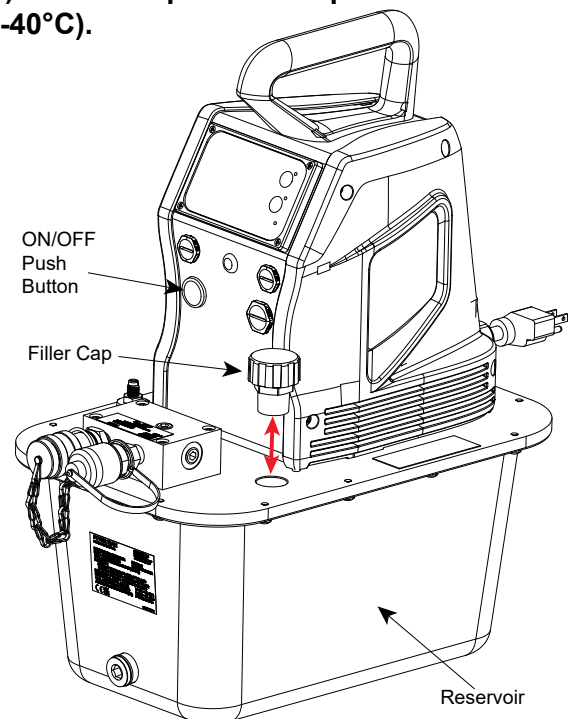

Fig. 11: PE60 Pump Reservoir

Pump Set-Up Instructions Continued

3. Connecting Electric Pump to the eSync Unit (Corded)

Please follow the instructions below to connect the PE60 Electric pump to the eSync unit.



- **The correct voltage is required for the pump to operate. Verify the voltage rating on the eSync power source you are using. Low voltage may cause: an overheated motor; a motor that fails to start under load; motor surging when trying to start; or a stalled motor before maximum pressure is reached.**
- **Ensure that pumps rated for 115V are connected only to eSync unit with a 115V capacity. Similarly, pumps rated for 230V must be connected to eSync units that support 230V. Failure to comply may result in equipment damage or safety hazards.**

- A. The PE60 pump features a standard protective and stackable uCage designed for attachment to the eSync uCage.
- B. Connect the PE60 pump cage to the eSync cage using the U-Bracket, T-Handle Lock Pin, Screw, Washer, and Nut that are supplied with the pump unit (see figure 12).
- C. Make sure no buttons on the hand pendant or on the eSync control panel are pressed, and the pump unit push button switch is in the OFF position (see figure 11).



Before connecting and operating the pump unit, ensure that all hydraulic connections between both units are properly established.

- D. Locate the power cord of the pump unit. It should have a plug at the end that matches the eSync socket you will be using.
- E. Align and firmly push the plug into the eSync until it is fully inserted. Ensure that it fits securely and there are no loose connections (see figure 12).
- F. When the eSync unit is powered ON, electricity will be supplied to the pump unit. To activate the pump motor and to supply fluid to the eSync system, set the pump ON/OFF switch to the ON position.

NOTE:

- **When the E-STOP button is pressed or the eSync unit is turned off, the pump unit will cease operation.**
- **The pump unit can be turned ON or OFF independently using the ON/OFF push button switch (see fig. 11).**

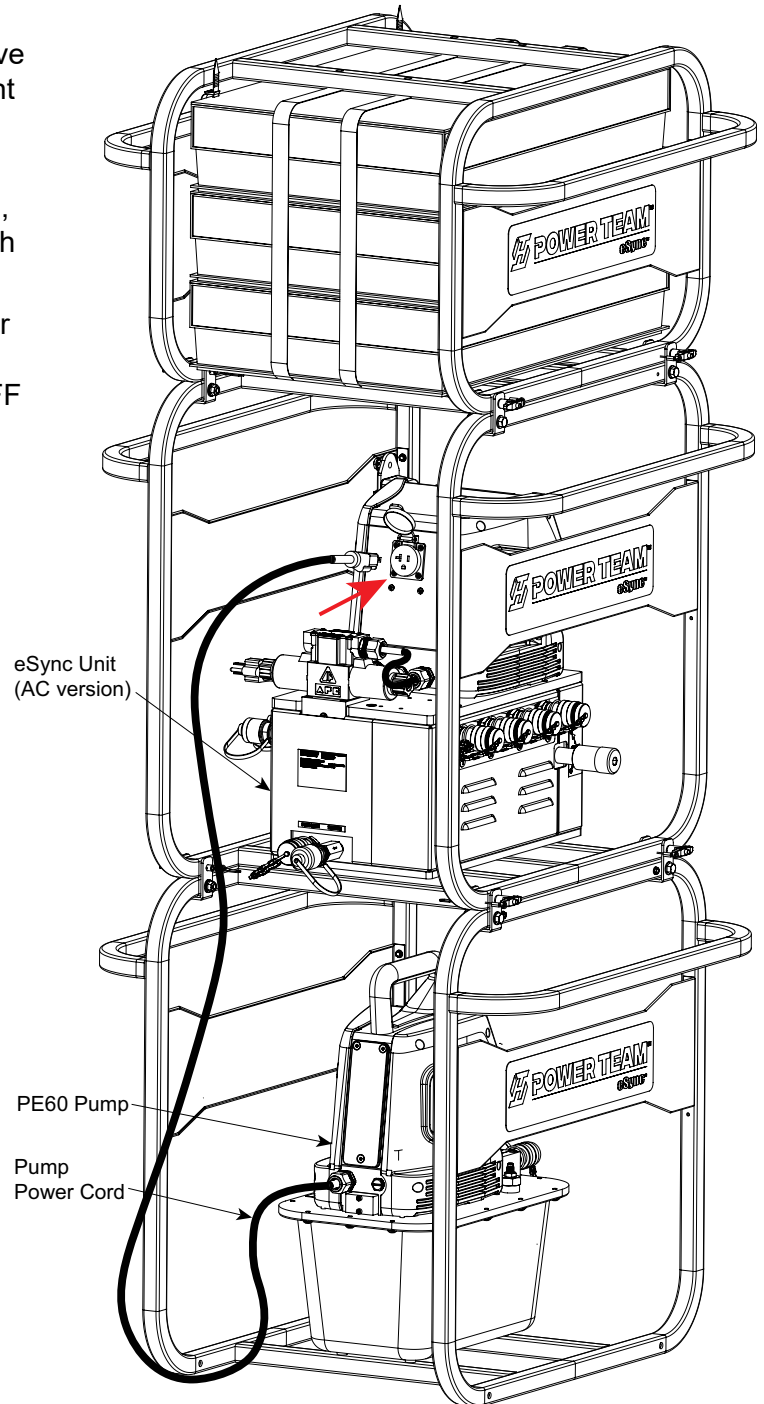

Fig. 12: PE60 Pump to eSync Connection

Pump Set-Up Instructions Continued

4. Connecting Battery Pump to the eSync Unit (Cordless)

Please follow the instructions below to connect the PB43 Battery pump to the eSync unit.

- A. The PB43 pump features a standard protective and stackable uCage designed for attachment to the eSync uCage (see figure 13).

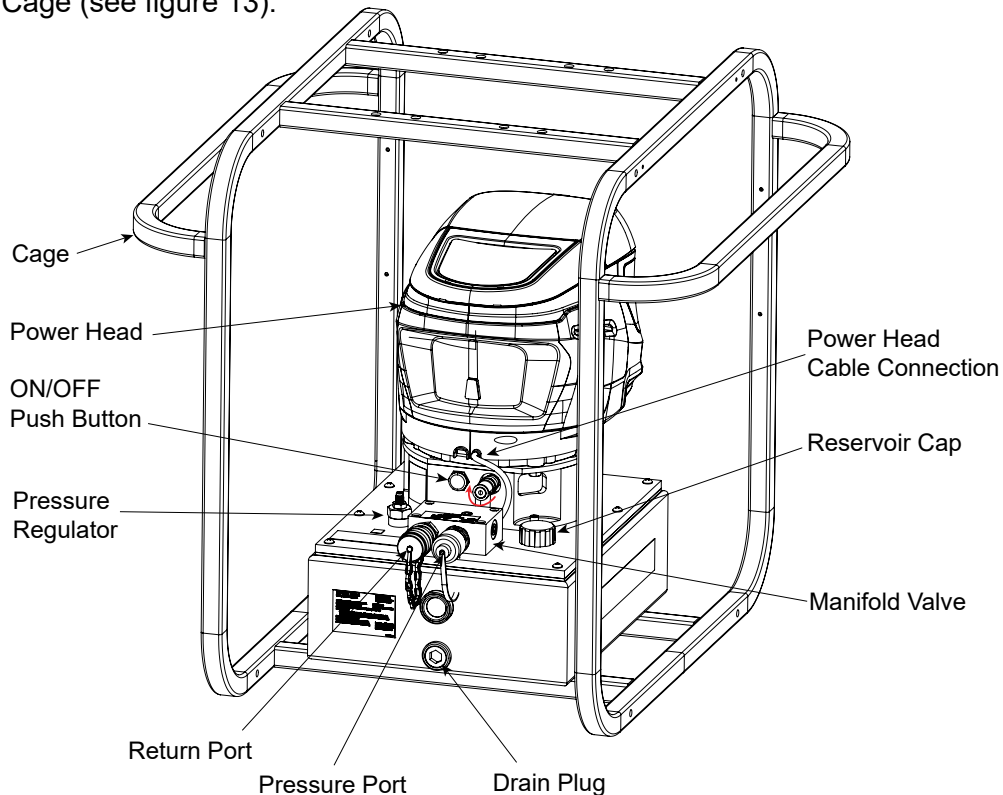

Fig. 13: PB43 Pump Unit

- B. Before connecting the pump to the eSync unit, verify the battery capacity level to confirm it is fully charged; if not, charge it before inserting it into the PB43 pump power head.

⚠ WARNING

- Please adhere to the specified **Battery Operating Temperature range of -4°F to 104°F (-20°C to 40°C)** and the **Battery Charging Temperature range of 41°F to 104°F (5°C to 40°C)**. Operating or charging the battery outside of these specified temperatures may cause damage to the battery and increase the risk of fire.
- C. To insert the battery pack into the power head, open and hold the battery door on the power head.
- D. Align the ribs on the battery and the battery bracket. Push the battery pack into the battery compartment until you hear a "click" (see figure 14).

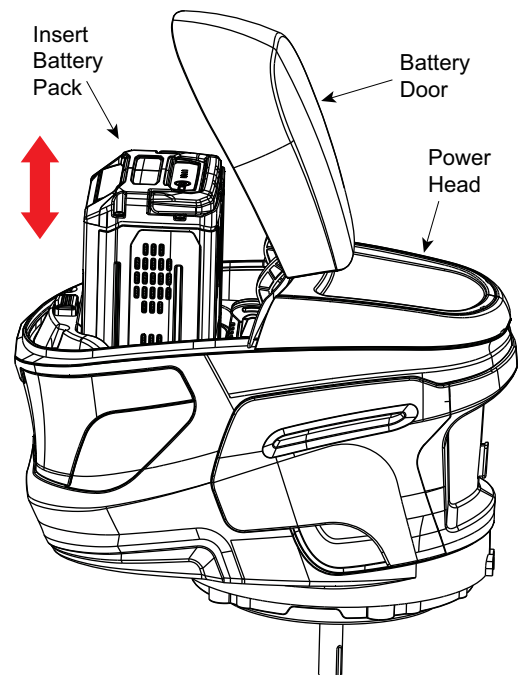

Fig. 14: Battery Pack Installation

Pump Set-Up Instructions Continued

- E. Insert the safety key into the key slot as shown below.
- F. Once the battery is fully seated and secured close the battery door on the power head.

NOTE: The pump can only be started when the safety key is inserted. Remove the safety key the power head after use.

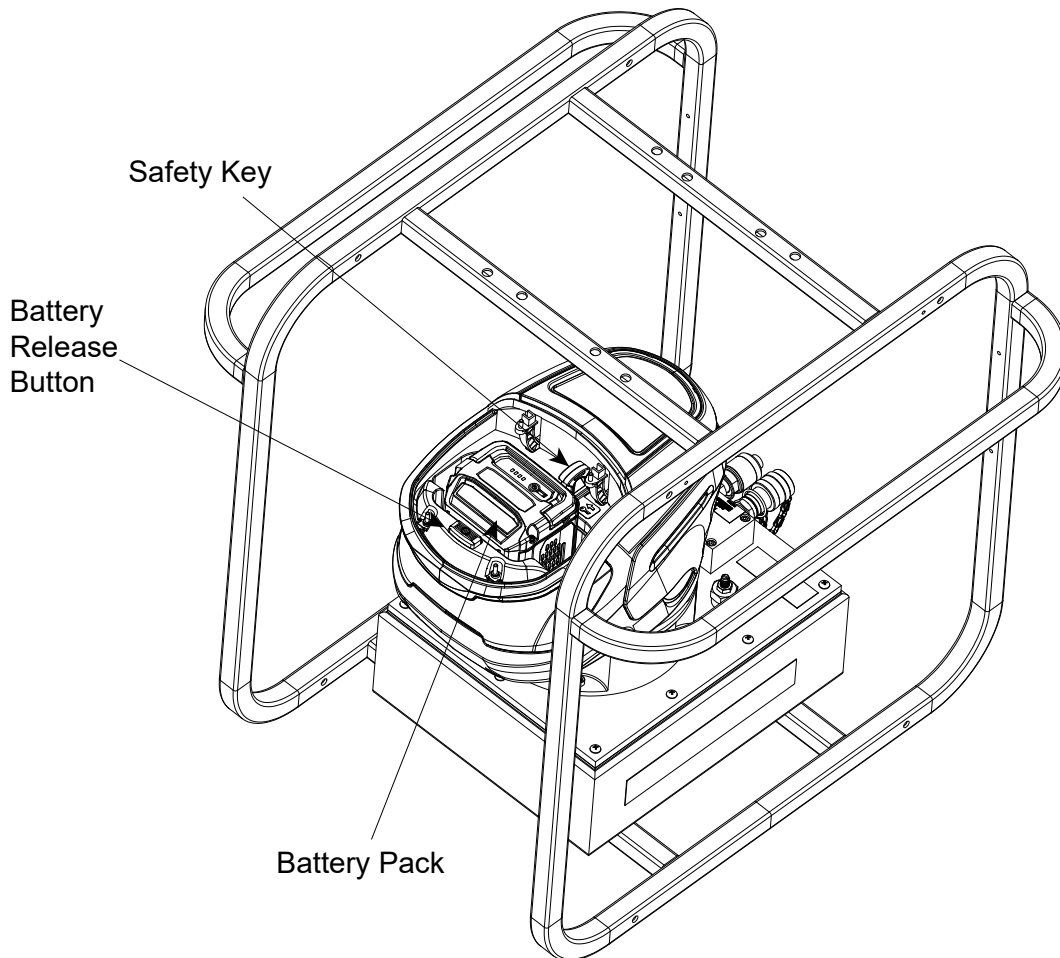

Fig. 15: Safety Key Insertion

⚠ WARNING : Remove the battery pack from the pump unit when it is not in use. Leaving the battery installed for an extended period of time can lead to complete drainage, which may cause battery failure and damage the equipment.

- G. Connect the power head female cable connector with male connector located on the pump unit. Secure the connection by threading (rotating clockwise) the cable fitting into the pump unit fitting, as shown in figure 13.
- H. This concludes the PB43 pump setup prior to linking it to the eSync unit.
- I. Connect the PB43 pump cage to the eSync cage using the U-Bracket, T-Handle Lock Pin, Screw, Washer, and Nut that are supplied with the pump unit (see figure 16).
- J. To establish communication between the eSync unit and the PB43 pump, both units must be connected using the pump tether cable that is provided with the pump unit.

Pump Set-Up Instructions Continued

- K. Connect one end of the tether cable's female connector to the male connector on the PB43 pump unit. Then, connect the male connector on the other end of the cable to the female connector on the eSync unit (see figure 16).

⚠ WARNING : Before connecting and operating the pump unit, ensure that all hydraulic connections between both units are properly established.

- L. To verify the connection between the two units, press the ON/OFF button on the pump unit and the Power Up button on the eSync unit. Ensure that none of the buttons on the hand pendant or the eSync control panel are being pressed.

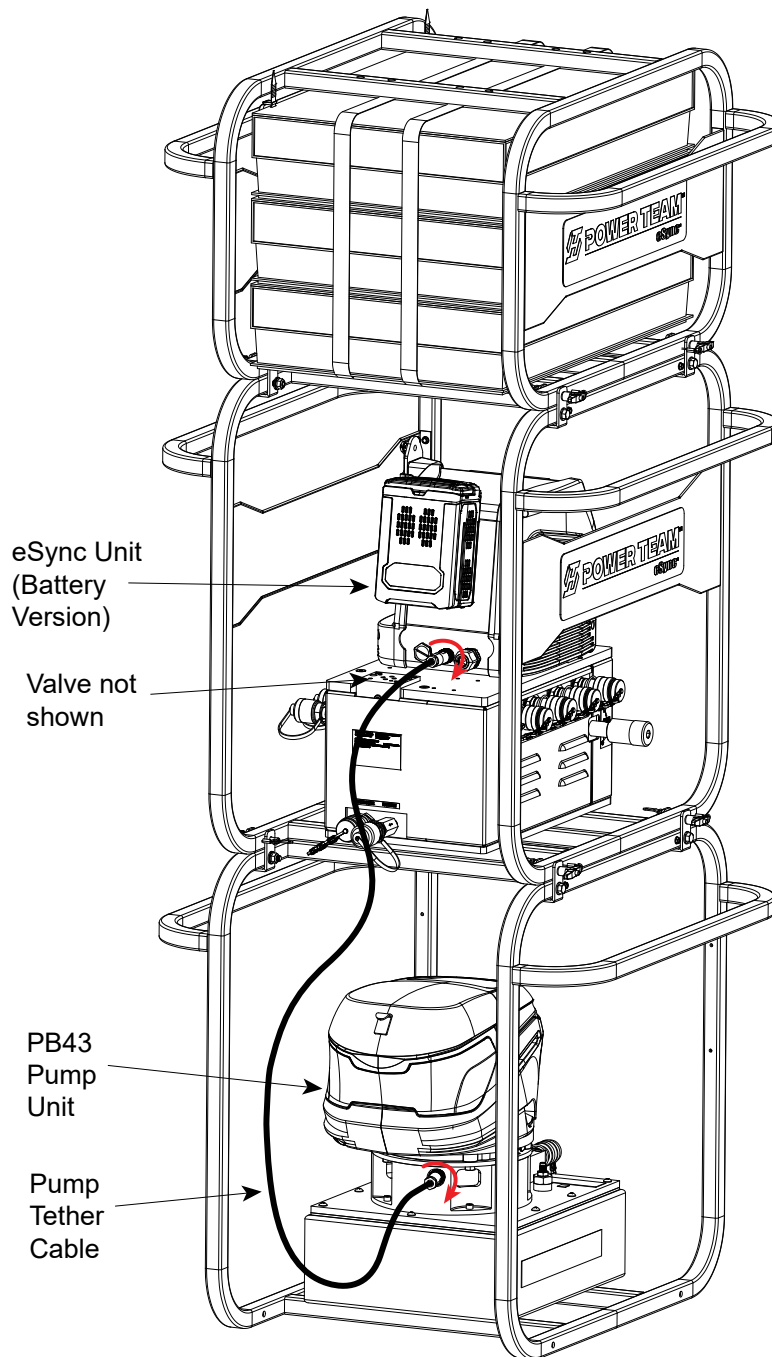

Fig. 16: PB43 Pump to eSync Connection

Pump Set-Up Instructions Continued

5. Bleeding Air from the System

After all connections are made, the hydraulic system must be bled of any trapped air. Refer to the diagrams below.

With no load on the system and the pump vented and positioned higher than the cylinder or hydraulic device, cycle the system several times. Check the reservoir for a possible low fluid level and fill it to the proper level with approved, compatible hydraulic fluid as necessary (see section "Filling the Pump Reservoir" under section "Pump Set-Up Instructions"). If there is a problem, contact the Power Team.

IMPORTANT: Some spring return cylinders, or rams have a cavity in the rod which forms an air pocket. This type of cylinder or ram should be bled when positioned upside down or lying on its side with the port facing upward.

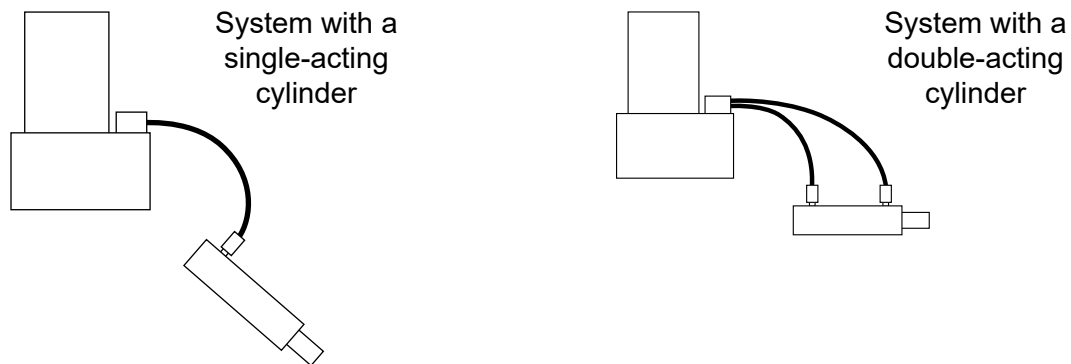

Fig. 17: Air Bleeding Method

LCD SCREEN FUNCTIONS

The following LCD screen functions describe the detailed options and settings available for the eSync unit. The LCD is driven and operated by a set of two boards: the power board and the control board (LCD), connected to each other.

CAUTION: The control board is an electrostatic sensitive device. Special care has to be taken while servicing this board.

1. LCD Operational Buttons

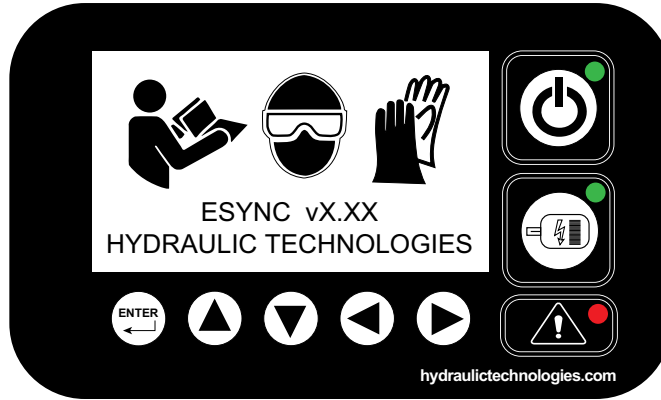

Screen 1. LCD Display

Buttons/Symbols	Functions
	ON/OFF - Used to turn the system ON and OFF.
	PUMP MOTOR - Used to turn the motor ON and OFF.
	ENTER - Used to access the "MENU MODE" and select specific options.
	UP ARROW - Used for moving the cursor in an upward direction and adjusting the values.
	DOWN ARROW - Used for moving the cursor in a downward direction and adjusting the values.
	LEFT ARROW - Used for moving the cursor in the left direction.
	RIGHT ARROW - Used for moving the cursor in the right direction.
	FAULT LIGHT - Illuminates when a fault error is detected.

LCD Screen Functions Continued

2. LCD Startup Splash Screen

- A. Connect the power cord to an appropriate power source.
- B. Refer to Screen 4. Press the ON/OFF button; the LCD screen will show the firmware version and safety symbols. Power will be supplied to the eSync unit and hand pendant.

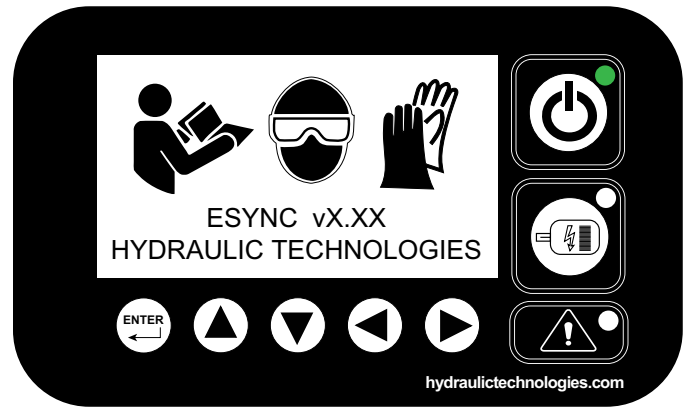

Screen 4

- C. Refer to Screen 5. After POWER UP the unit will perform a system check. If critical fault(s) are detected, unit will not start, and fault(s) will be displayed with an LED flashing RED light and error on the LCD screen. Warnings will not prevent the unit from powering up.
- D. Six dots will light up in sequential order (from left to right) during the system check, and "OK" will appear once the system check has finished successfully.

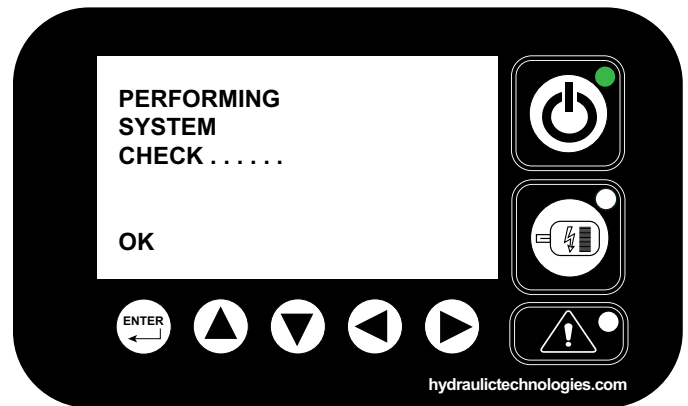

Screen 5

- E. Use the "▲▼" and "◀▶" buttons to set the date in "DD/MM/YY" format, then press the "ENTER" button (Refer to screen 6).

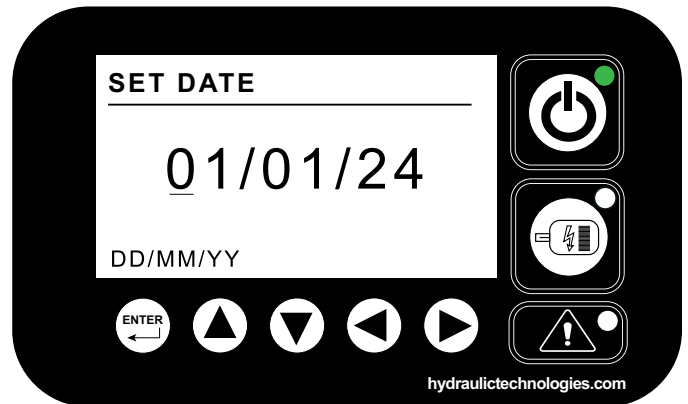

Screen 6

- F. Use the "▲▼" and "◀▶" buttons to set time in 24 hours format then press the "ENTER" button (Refer to screen 7).
- G. After completing the above settings, the LCD will show an output screen.

NOTE: If the unit is disconnected from a power source or experiences a power loss, the date and time will require re-entry. However, if the unit is switched on or off while maintaining a consistent power supply, no additional input is necessary except during the initial power-up.

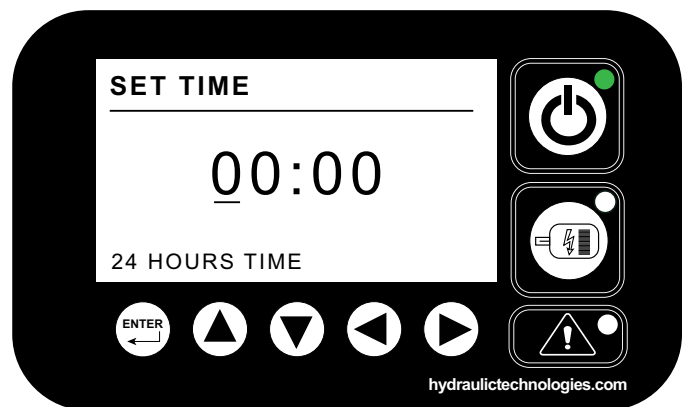

Screen 7

LCD Screen Functions Continued

3. Output Screen Overview

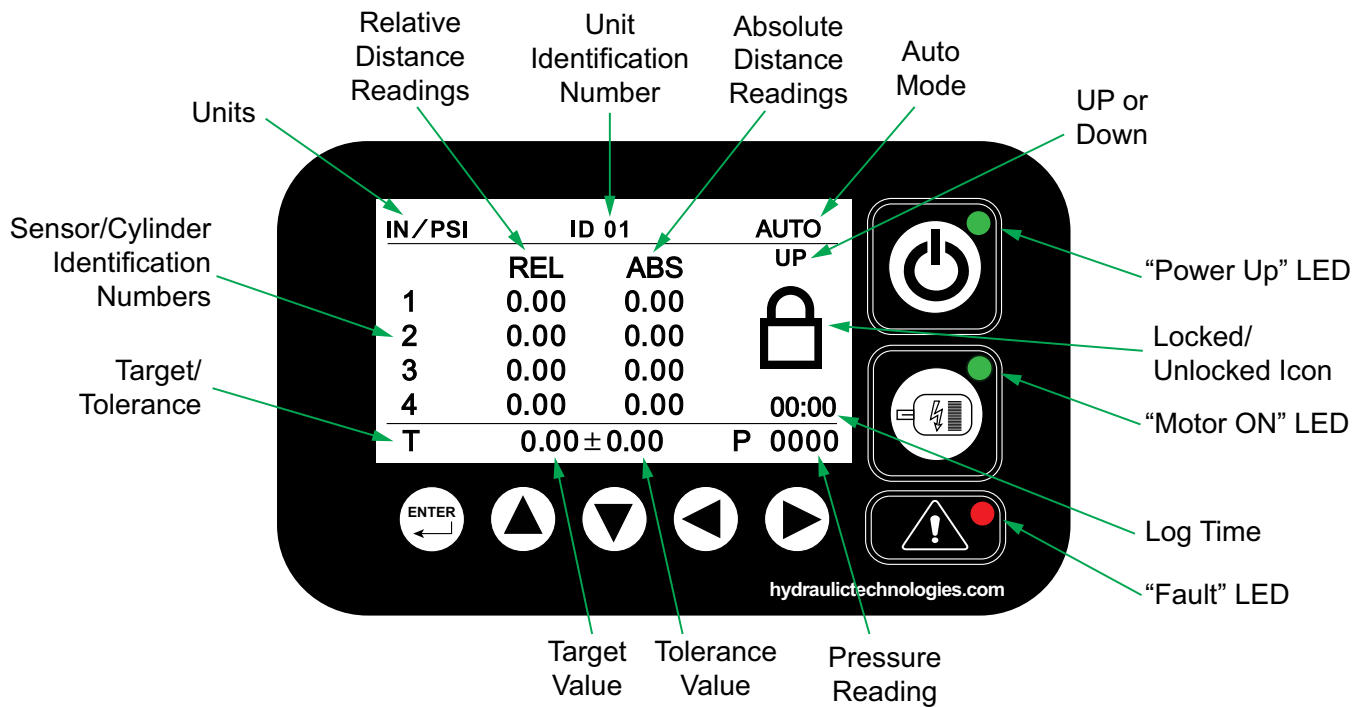

Output Screen (Auto Mode)

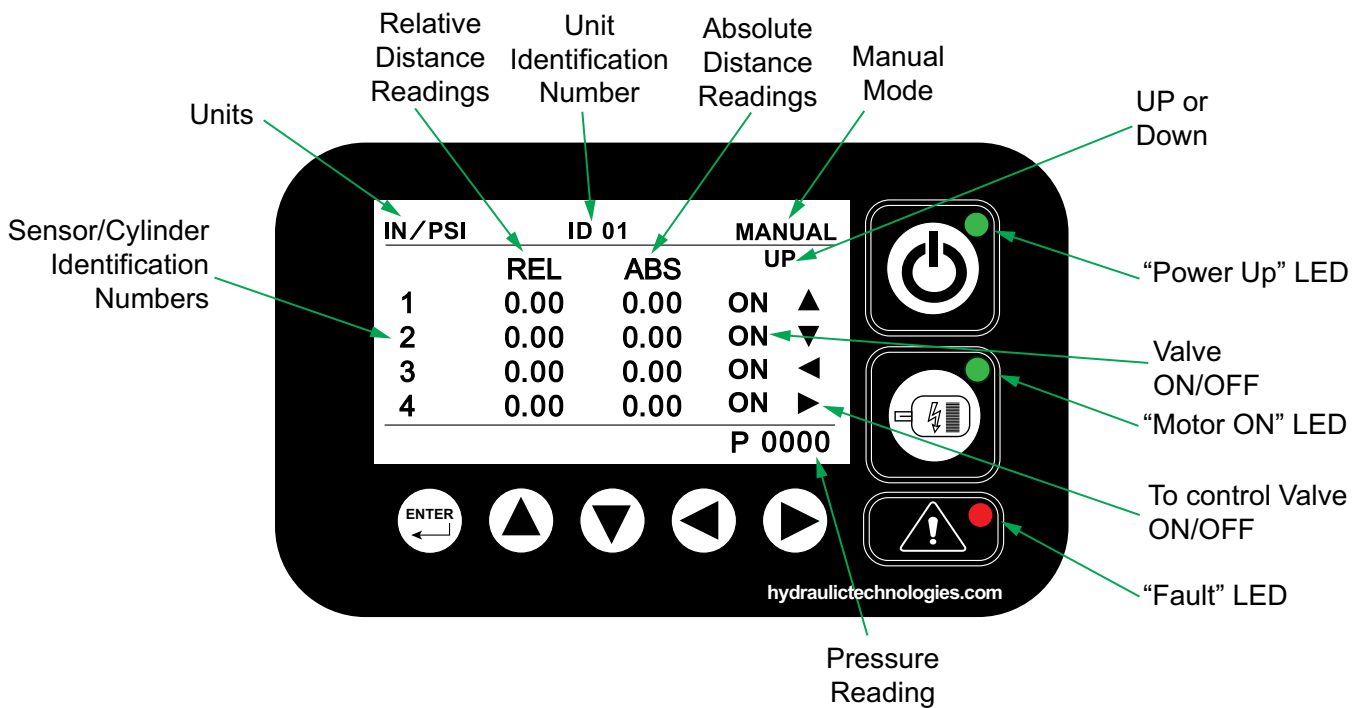

Output Screen (Manual Mode)

LCD Screen Functions Continued

4. Main Menu Options

A. To enter the “MENU MODE”, press the “ENTER” button. The pump motor must be off to enter this mode. Screens 1, 2 and 3 show the options available in Menu Mode.

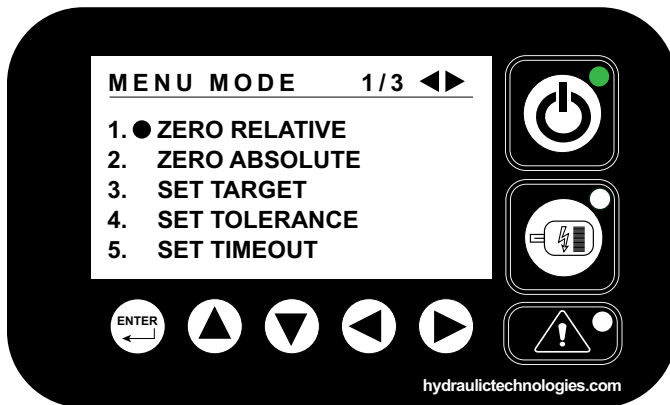

Screen 1

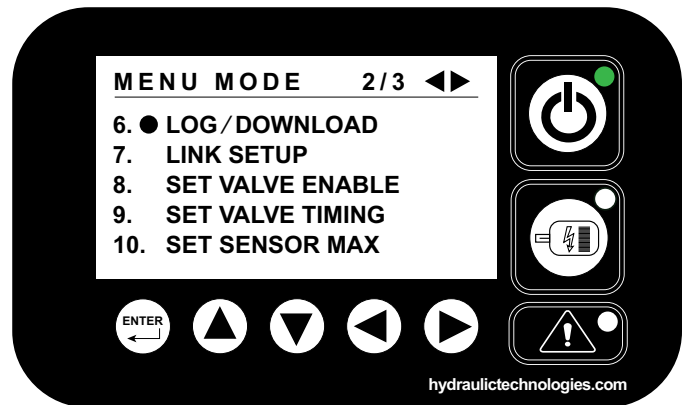

Screen 2

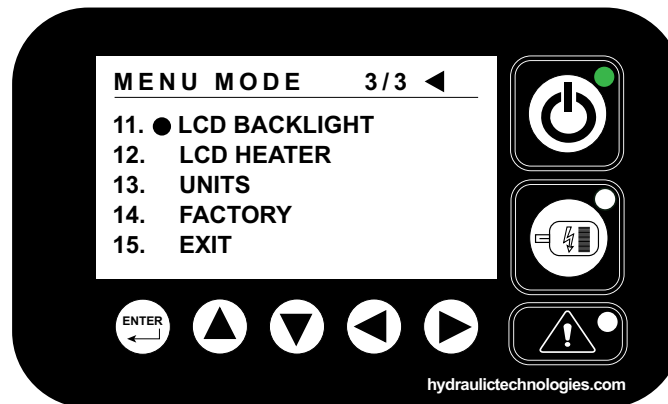

Screen 3

B. Use the “▲▼” buttons to select the desired menu mode, then press the “ENTER” button.

C. To return to the “MENU MODE” from the desired mode, press the “◀” button.

General Notes for MENU MODE:

- Settings made during the last operation will be saved to memory for future use.
- Pressing the “◀” will bring you back to one screen (when available).
- Pressing the “◀” multiple times will bring you back to the “OUTPUT SCREEN”.
- Pressing the “▶” will move you forward one screen (when available).
- Choosing “EXIT” and pressing the “ENTER” button will bring you back to the “OUTPUT SCREEN”.
- Users can enter into “MENU MODE” with the motor only in off state.
- The options set as default or selected will have a black background or white text.
- At each step, be sure to press the "ENTER" button so that data is stored in the program.
- The options set as default or selected will have black background/white text.

LCD Screen Functions Continued

The selections for the various menu mode options are displayed in the structure below.

A. ZERO RELATIVE

1. SENSOR 1
2. SENSOR 2
3. SENSOR 3
4. SENSOR 4
5. ALL SENSORS

B. ZERO ABSOLUTE

1. SENSOR 1
2. SENSOR 2
3. SENSOR 3
4. SENSOR 4
5. ALL SENSORS

C. SET TARGET

D. SET TOLERANCE

E. SET TIMEOUT

F. LOG/DOWNLOAD

1. MODE
2. TIME
3. DATE
4. INTERVAL
5. DOWNLOAD / RESET

G. LINK SETUP

1. MODE
2. NODE ID
3. UNLOCK/DISCOVER
4. EXIT

H. SET VALVE ENABLE

1. ON/OFF
2. ON/OFF
3. ON/OFF
4. ON/OFF
5. EXIT

I. SET VALVE TIMING

1. UP ON
2. UP OFF
3. DOWN ON
4. DOWN OFF
5. EXIT

J. SET SENSOR MAX

1. SENSOR 1
2. SENSOR 2
3. SENSOR 3
4. SENSOR 4
5. ALL SENSORS

K. LCD BACKLIGHT

1. LOW
2. MEDIUM
3. HIGH
4. EXIT

L. LCD HEATER

1. LOW
2. MEDIUM
3. HIGH
4. EXIT

M. UNITS

1. IN/PSI
2. MM/BAR
3. EXIT

N. FACTORY

Note: The factory reset option is not permitted for user access.

O. EXIT

LCD Screen Functions Continued

A ZERO RELATIVE

This is used to set the zero position on each sensor to align all lifting cylinders at the reference point. This ensures that all cylinders start from the same relative position before lifting the load.

A relative position can be considered your working position. Specifically, it is the distance that the displacement sensor is extended relative to its previous position at the time of zeroing out the sensor.

- i. Use the “▲▼” buttons to select "ZERO RELATIVE" from "MENU MODE", then press the “ENTER” button (Refer to screen 1).
- ii. Use the “▲▼” buttons to select specified or all sensors, then press the “ENTER” button (Refer to screen A.1).
- iii. Once you press the "ENTER" button, the output screen will be displayed with zero relative values (Refer to screen A.2).

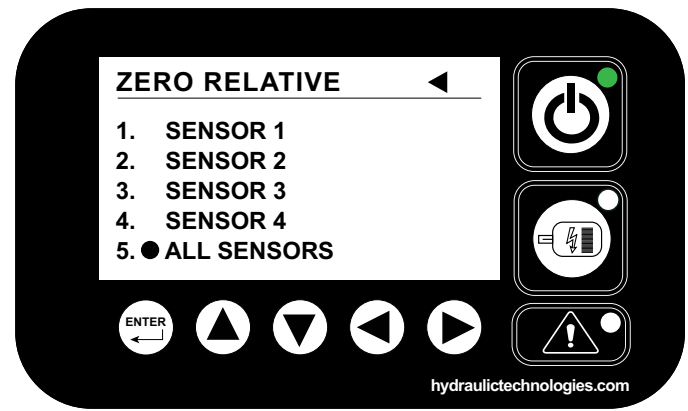

Screen A.1

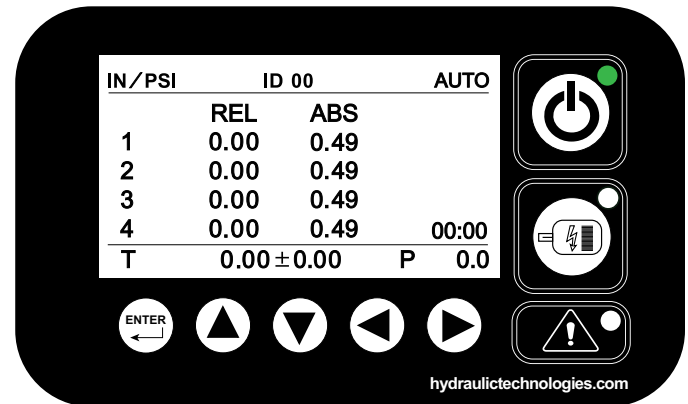

Screen A.2

B. ZERO ABSOLUTE

The absolute position is the position of the cylinder's displacement sensor relative to its starting point zero, only if the sensor is mounted to the cylinders and not the load. This would be achieved by mounting the sensor to the cylinder body and the sensor wire to the cylinder cap on the ram. If the load is connected, zero absolute can be done at the same time as zero relative.

The "ZERO ABSOLUTE" reading is set as the reference point to ensure uniformity and synchronization among all lifting cylinders in the system and is set to ZERO when all cylinders are in their lowest position and before preload.

By defining the "ZERO ABSOLUTE" reading, ensures that all cylinders start from the same position.

- i. Use the “▲▼” buttons to select "ZERO ABSOLUTE" from "MENU MODE", then press the “ENTER” button (Refer to screen 1).
- ii. Use the “▲▼” buttons to select the required sensor or all sensors, then press the “ENTER” button (Refer to screen B.1).
- iii. Once you press the "ENTER" button, the output screen will be displayed with zero absolute values (Refer to screen B.2).

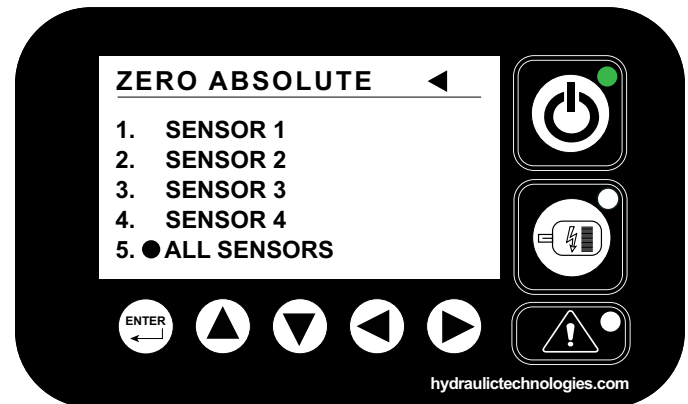

Screen B.1

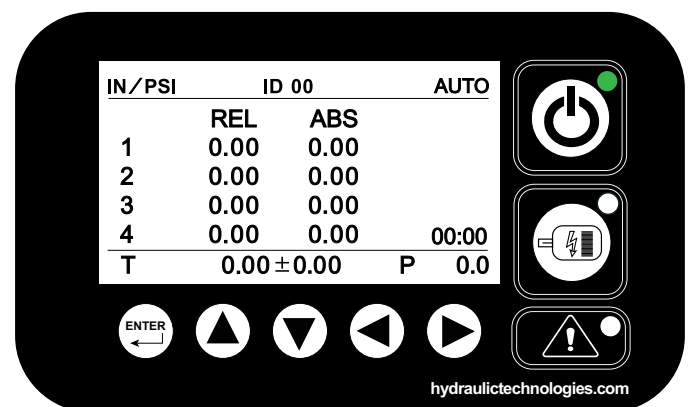

Screen B.2

LCD Screen Functions Continued

C. SET TARGET (AUTO MODE)

Enter the target height or position that all lift points reach simultaneously.

The set point position target has to be greater than the relative position of the cylinders to move the load up or down.

The maximum distance can be set to 1000 mm or 39.37 inch. Do not exceed maximum length of sensors used.

- i. Use the “▲▼” buttons to select "SET TARGET" from "MENU MODE", then press the “ENTER” button (Refer to screen 1).
- ii. To lift the load: use the “▲▼” and “◀▶” buttons to set the desired target value, then press the “ENTER” button to save the value (Refer to screen C.1).
- iii. To lower the load: use the “▲▼” and “◀▶” buttons to set value back to zero, then press the “ENTER” button (Refer to screen C.1).
- iv. Once you press the "ENTER" button, the output screen will be displayed with the target value (Refer to screen C.2).

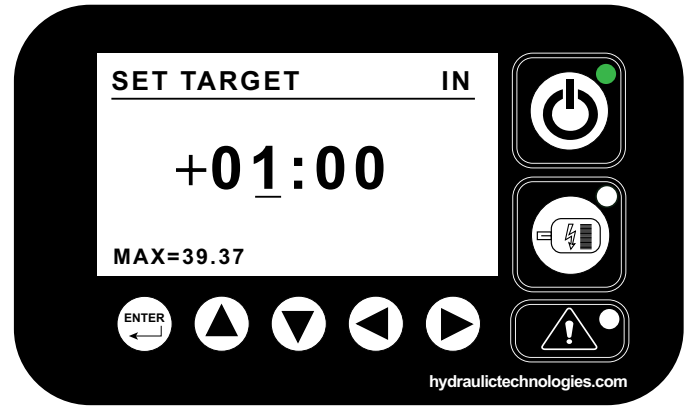

Screen C.1

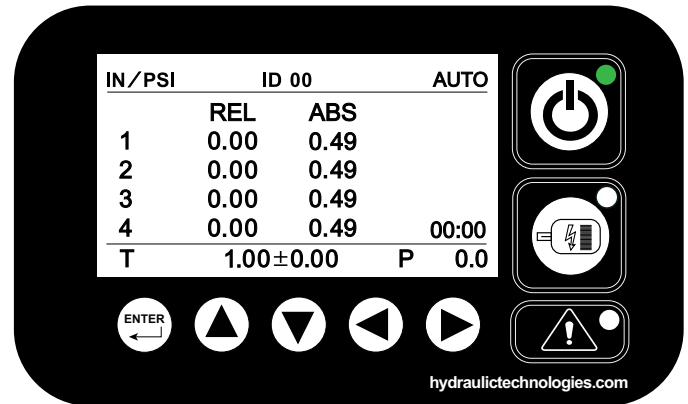

Screen C.2

D. SET TOLERANCE (AUTO MODE)

The tolerance value that ensures all active cylinders are synchronized during auto operations. It impacts all enabled cylinders during the 'Automatic Lift' and 'Automatic Lower' actions. The system maintains the set tolerance by constantly turning on and off individual cylinders, ensuring that they remain within the set range (tolerance).

- i. Use the “▲▼” buttons to select "SET TOLERANCE" from "MENU MODE", then press the “ENTER” button (Refer to screen 1).
- ii. Use the “▲▼” and “◀▶” buttons to set the desired tolerance value, then press the “ENTER” button to save the value (Refer to screen D.1).

E.g., if the tolerance is set to 0.1 inch, the maximum distance between the least extended cylinder and the most extended cylinder during operation will be within 0.1 inch (Refer to screen D.2).

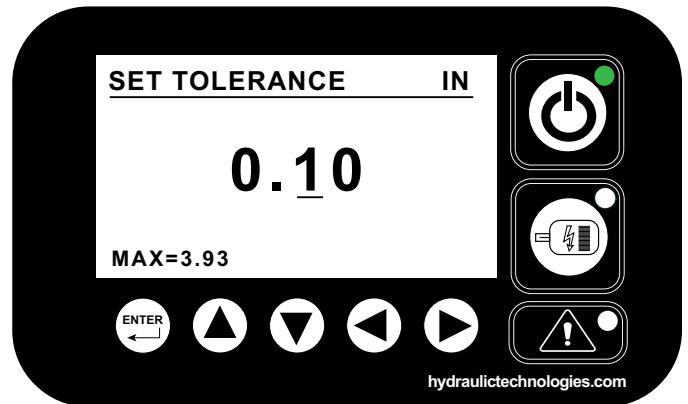

Screen D.1

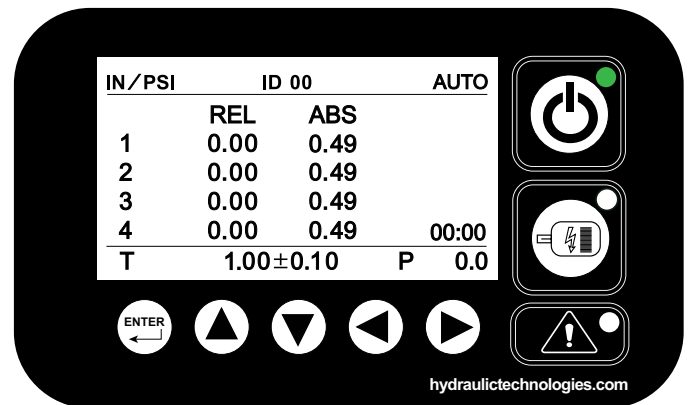

Screen D.2

LCD Screen Functions Continued

E. SET TIMEOUT

The primary purpose of the "SET TIMEOUT" feature is to notify the user when there is no movement of the cylinder plunger or activity in the lifting system beyond a specified time threshold. If the system remains inactive for longer than the defined timeout period, the feature triggers an alert or safety action to prevent potential hazards or issues that may arise from prolonged inactivity.

It also gives the valve count during UP and DOWN cycles within the user's specified timeout value. The valve count is determined by the user input provided on the screen E.1 and the valve timing settings on screen I.1. For example, if the user enters 2 seconds on the screen E.1 and the valve timing for the "UP" is set at 100 milliseconds, the valve count will be calculated as follows: 2000 MS (2 seconds) divided by 100 MS (valve timing) equals 20. Therefore, the "UP CYCLES" count would be 20 in this scenario.

- i. Use the "▲▼" buttons to select "SET TIMEOUT" from "MENU MODE", then press the "ENTER" button (Refer to screen 1).
- ii. Use the "▲▼" and "◀▶" buttons to set the required time duration, then press the "ENTER" button to save the value (Refer to screen E.1).

F. LOG/DOWNLOAD

The logging feature serves the purpose of recording user actions, system events, and operational data to provide a detailed history of the lifting operation.

NOTE: This functionality is only operational in "AUTO" mode and is not available in "MANUAL" mode.

- i. Use the "▲▼" buttons to select "LOG/DOWNLOAD" from "MENU MODE", then press the "ENTER" button (Refer to screen 2).
- ii. Use the "▲▼" buttons to select "MODE" from the "LOG/DOWNLOAD" screen, then press the "ENTER" button (Refer to screen F.1).
- iii. On the next screen "LOGGING MODE", select "YES" to enable the logging feature (Refer to screen F.2).
- iv. Use the "▲▼" buttons to select "TIME" from the "LOG/DOWNLOAD" screen, then press the "ENTER" button (Refer to screen F.1).
- v. Use the "▲▼" and "◀▶" buttons to set time in 24 hours format then press the "ENTER" button (Refer to screen F.3).

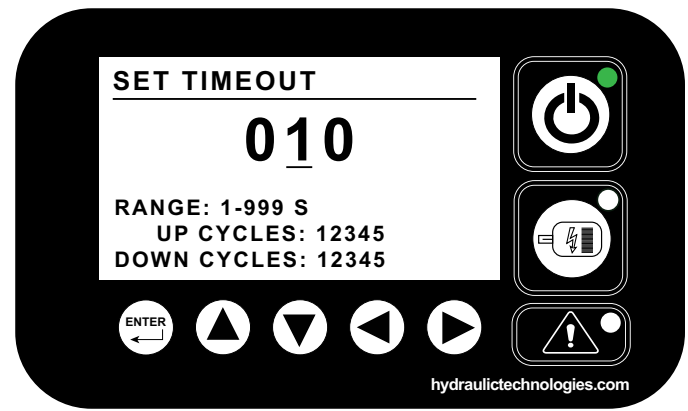

Screen E.1

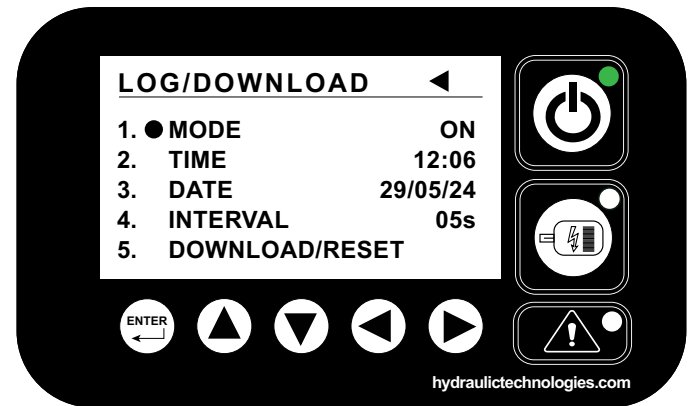

Screen F.1

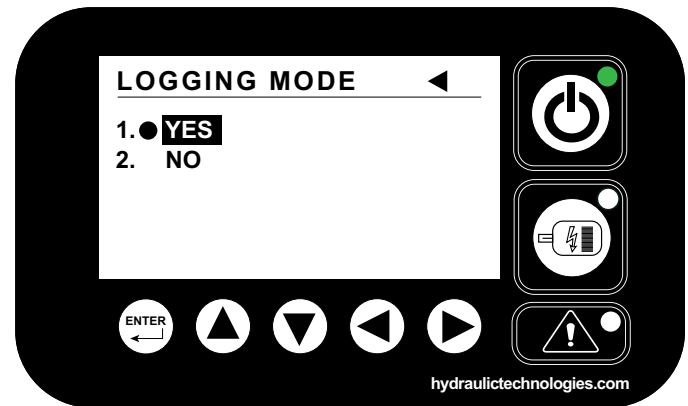

Screen F.2

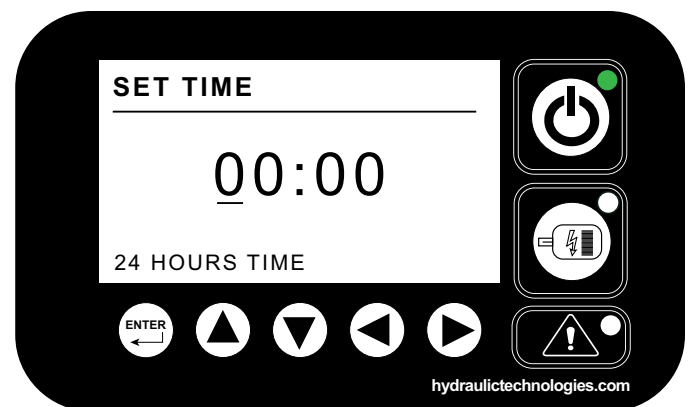

Screen F.3

LCD Screen Functions Continued

- vi. Use the “▲▼” buttons to select "DATE" from the "LOG/DOWNLOAD" screen, then press the “ENTER” button (Refer to screen F.1).
- vii. Use the “▲▼” and “◀▶” buttons to set the date in "DD/MM/YY" format, then press the “ENTER” button (Refer to screen F.4).
- viii. Use the “▲▼” buttons to select "INTERVAL" from the "LOG/DOWNLOAD" screen, then press the “ENTER” button (Refer to screen F.1).
- ix. On the next screen, adjust the "LOGGING INTERVAL" time within the range of 1 to 999 seconds. As shown on screen F.5, setting the log interval time to 10 seconds results in a total log record time of 01:28:20 hours. When the log interval time is modified from 10 seconds to 20 seconds, the total log record time will automatically adjust to 02:56:40 hours before overwriting begins.

NOTE: The log interval time should be determined by the duration of the lifting or lowering operation, and it must exceed the operation time. For instance, if a user has a 10-hour work period, the log time should be set to at least 10 hours or more to ensure comprehensive recording of all activities.

- x. Use the “▲▼” buttons to select "DOWNLOAD/RESET" from the "LOG/DOWNLOAD" screen, then press the “ENTER” button (Refer to screen F.1).
- xi. Select "DOWNLOAD" option by pressing enter button. The system will then check for the presence of a USB drive and begin transferring log details. If no USB is detected, the screen will begin blinking constantly, displaying the USB icon (Refer to screen F.6).

This feature enables operators to download detailed logs of lifting operations, user actions, system events, and other relevant information.

- xii. To reset the system's log details, select the "RESET" option on screen F.6 under the "DOWNLOAD/RESET" menu. Next, select the CONFIRM option on the subsequent screen F.7 to reset all log details. If you wish to cancel the reset operation, choose the CANCEL option instead.

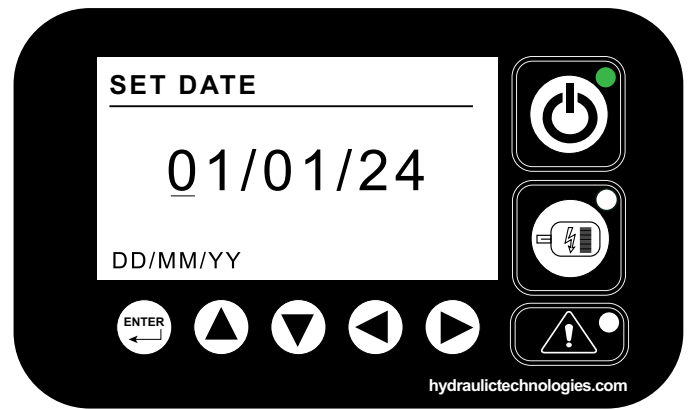

Screen F.4

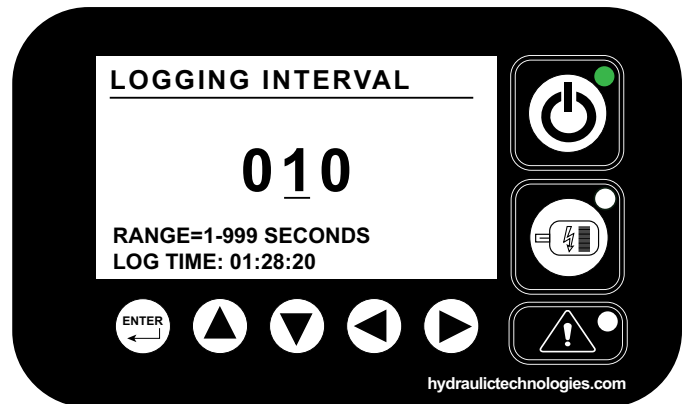

Screen F.5

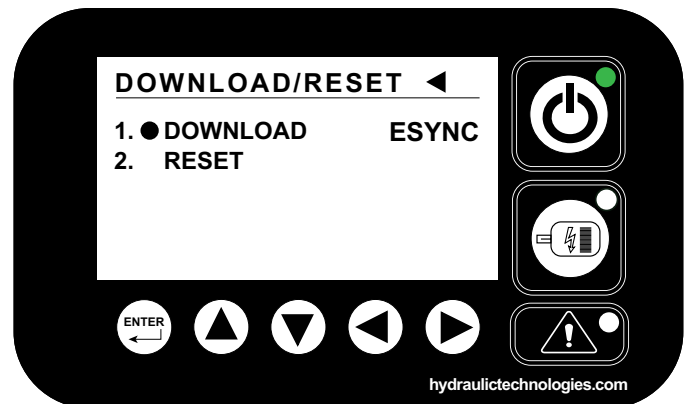

Screen F.6

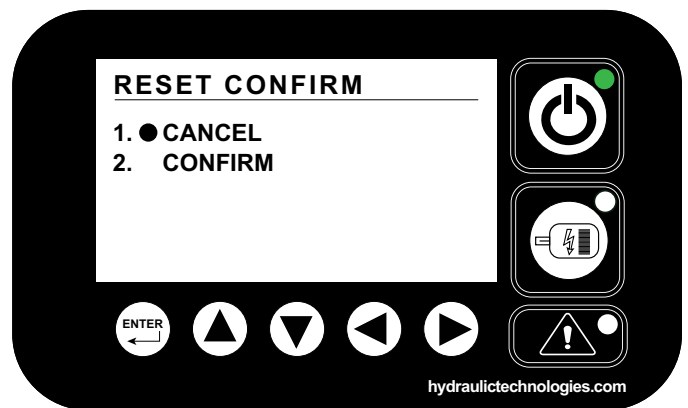

Screen F.7

LCD Screen Functions Continued

G. LINK SETUP

The "LINK SETUP" feature is used to interconnect multiple eSync units within a synchronous lifting system. When integrating multiple units, it is important to select one of the units as the master unit, a selection that can be made from any of the units. Each unit must be assigned a unique ID number between 1 and 16, enabling the master unit to readily identify and differentiate between the interconnected units.

NOTE: Prior to starting, ensure that all units are connected via signal cables as outlined in the "Connecting Multiple eSync Units" section and each unit has a unique ID.

For Master Unit setup:

Identify the unit that will be configured as the master unit, and then follow the instructions below.

- i. Use the "▲▼" buttons to select "LINK SETUP" from "MENU MODE", then press the "ENTER" button (Refer to screen 2).
- ii. Select "ON" on the next screen G.1, then press the "ENTER" button to activate the linking mode for the master unit.
- iii. Use the "▲▼" buttons to select the "NODE ID" option on the "LINK SETUP" screen, then press the "ENTER" button to assign a unique ID number from 1 to 16 to the unit (Refer to screen G.2).
- iv. Use the "▲▼" and "◀▶" buttons to set the node ID number, then press the "ENTER" button to save the value (Refer to screen G.3).
- v. Now, screen G.4 displays the ID number and the "MODE" status, which is "LOCKED".

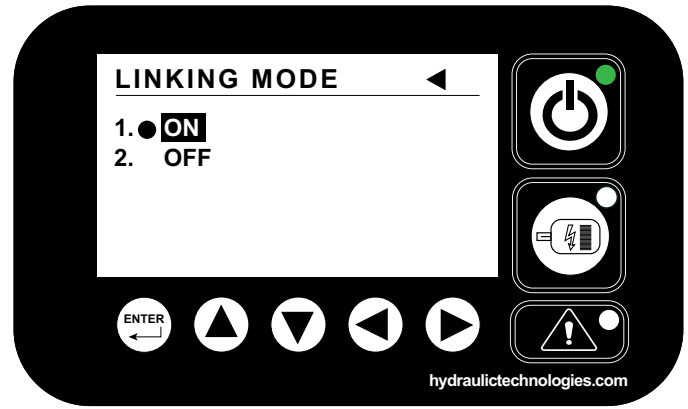

Screen G.1

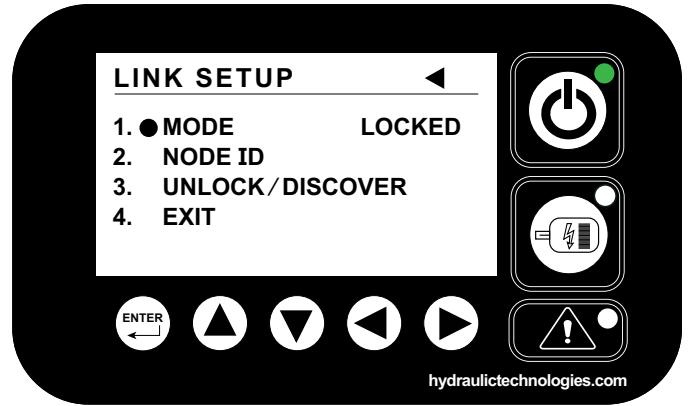

Screen G.2

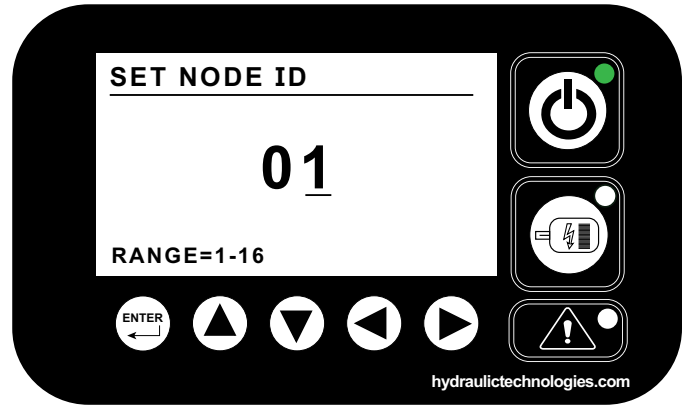

Screen G.3

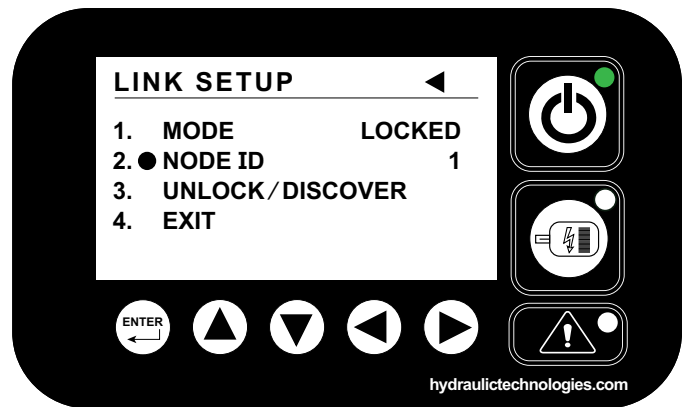

Screen G.4

LCD Screen Functions Continued

- vi. Choose the "UNLOCK / DISCOVER" option on the "LINK SETUP" screen, then press the "ENTER" button to designate this unit as the master unit (Refer to screen G.4).

NOTE: Before unlocking the master unit, ensure that all the secondary or linked units have the linking feature ON with a unique ID. The UNLOCK option should only be selected for the specific unit chosen to be the master, and should not be selected for any of the remaining units.

- vii. After selecting the "UNLOCK / DISCOVER" option, the system will begin identifying the linked units and display the ID numbers of the units linked to the master unit (Refer to screens G.5 and G.6).

- viii. Verify that the master unit has identified all linked units; if any of the units are missing "CANCEL" the process, check the settings in the linked units and repeat the above steps. If all units are identified, "CONFIRM" the settings by pressing the "ENTER" button (Refer to screen G.6).

- ix. Now, screen G.7 displays the ID number and the "MODE" status, which is "UNLOCKED".

- x. Once the above settings are completed, go to the output screen to ensure that the screen displays the UNLOCKED icon (Refer to screen G.8).

- xi. The LOCKED/UNLOCKED icon will be visible only in "AUTO" mode. If the unit is in "MANUAL" mode, switch it to "AUTO" mode using the hand pendant control to show UNLOCKED icon (Refer to screen G.8).

- xii. When it is successfully unlocked and set to "AUTO" mode, the hand pendant will be enabled to activate advance and retract operations. (Refer to the hand pendant operation section on page 43).

NOTE: The master unit pushes the parameters SET TARGET, SET TOLERANCE, UNITS OF MEASURE, and LOGGING FEATURE SETTINGS to the linked units, ensuring that all linked units carry the similar desired parameters.

NOTE: The LINK SETUP function allows you to set only one unit as the master unit. If two units are established as masters, the last unit UNLOCK/DISCOVER will override any other unit, making it into a linked unit and will be locked.

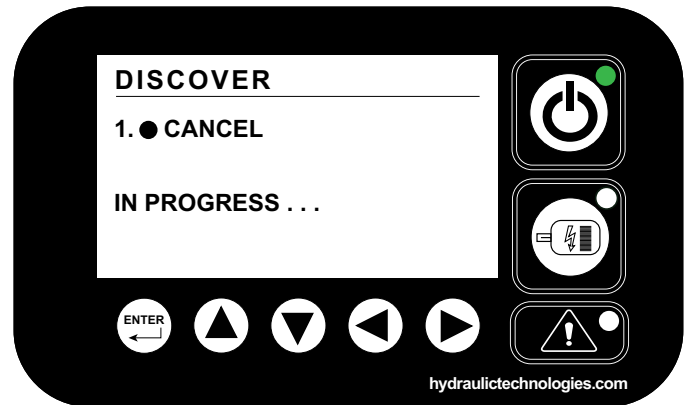

Screen G.5

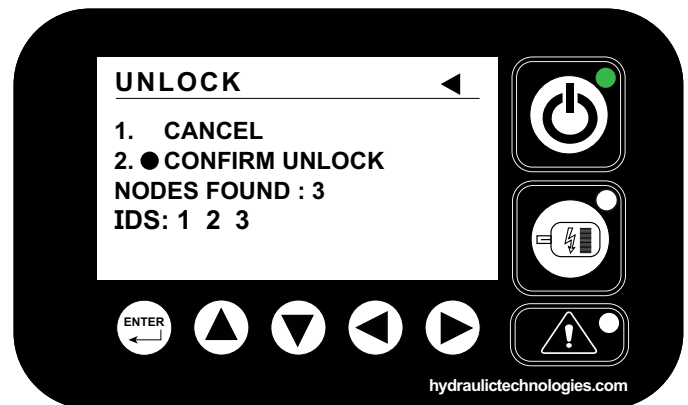

Screen G.6

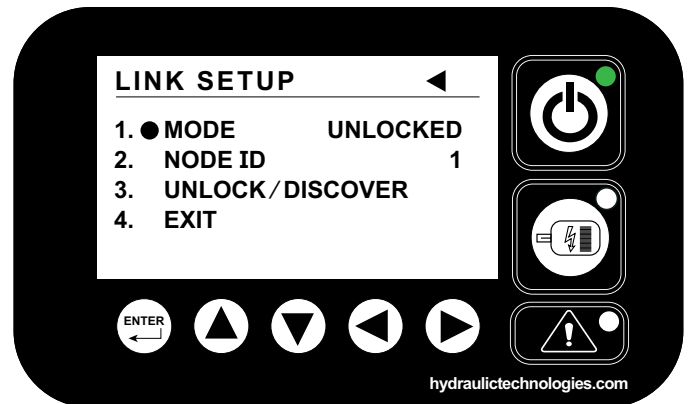

Screen G.7

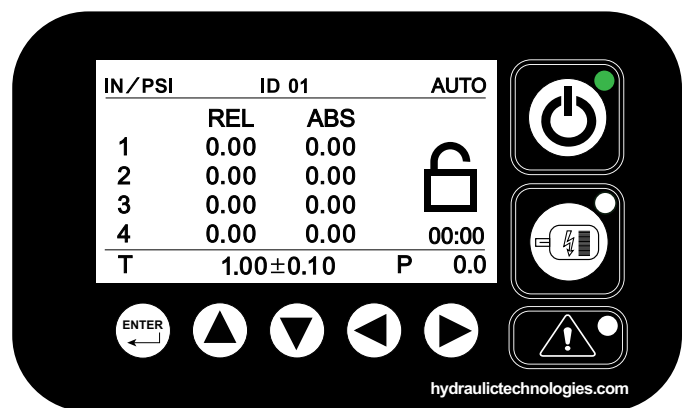

Screen G.8

LCD Screen Functions Continued

For Linked/Remote Units setup:

- i. Repeat the steps outlined above to turn linking mode ON and assign an ID number to the remaining units.

Note: The UNLOCK option should only be selected for the specific unit chosen to be the master, and should not be selected for any of the remaining units.

- ii. Once the above settings are completed, go to the output screen to ensure that the screen displays the LOCKED icon (Refer to screen G.9).
- iii. The LOCKED/UNLOCKED icon will be visible only in "AUTO" mode. If the unit is in "MANUAL" mode, switch it to "AUTO" mode using the hand pendant control to show the LOCKED icon (Refer to screen G.9).
- iv. When it is successfully LOCKED and set to "AUTO" mode, the hand pendant will be disabled for linked units.

NOTE: If the UNLOCK icon is displayed on the linked unit OUTPUT screen, it indicates that the unit will not be recognized by the master unit and can be activated using the hand pendant control.

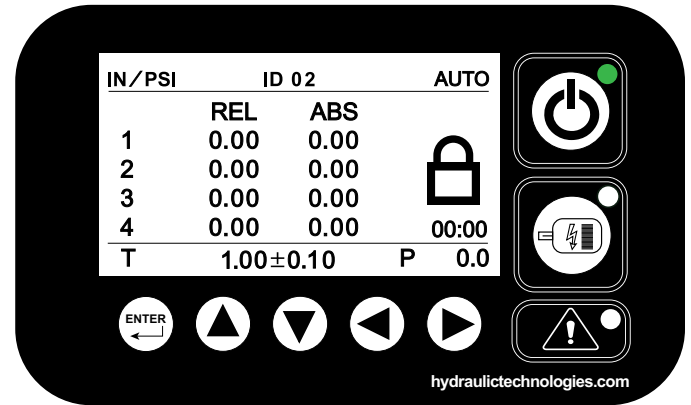

Screen G.9

H. SET VALVE ENABLE

The valve enabling feature allows for the controlled activation of hydraulic valves that direct the flow of fluid to the lifting cylinders.

By enabling or disabling specific valves, the operator can regulate the flow of hydraulic fluid to each lifting cylinder.

- i. Use the "▲▼" buttons to select "SET VALVE ENABLE" from "MENU MODE", then press the "ENTER" button (Refer to screen 2).
- ii. Use the "▲▼" buttons to select a specified valve, then press the "ENTER" button to disable the selected valve (Refer to screen H.1).

E.g., if valve 1 is in OFF condition, as shown on screen H.1, then the output screen will not show valve 1 and related parameters (Refer to screen H.2).

NOTE: Please note that if any of the valves are set to the OFF position, you will be unable to select parameters associated with that valve, such as Max Distance, Relative Zero, and Absolute Zero Values.

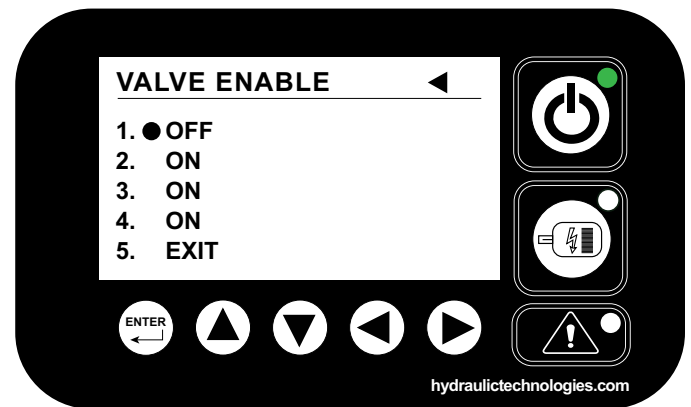

Screen H.1

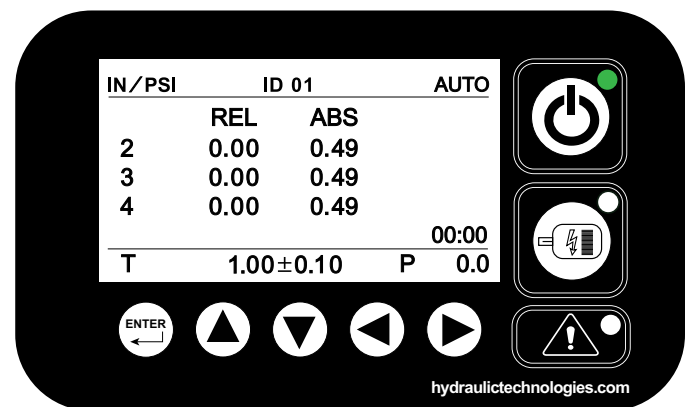

Screen H.2

LCD Screen Functions Continued

I. SET VALVE TIMING

The valve timing feature allows for precise timing of the opening and closing of hydraulic valves in each lifting cylinder.

Enter the time increment value within which the 2-way valves shall be operated. Start with a short time value. Depending on the size and capacity of the cylinders, the length of the hoses, and the pressure level needed for lifting, this time can be too short to allow for a reasonable lifting speed. Gradually increase the time during the operation and monitor the resulting overall accuracy. Too long actuation time will cause the cylinders to advance or retract in too large of steps, subsequently exceeding the preset tolerance. In this case, the micro unit will stop the operation, close all valves, and display an error on the output screen.

All valve timing is set in milliseconds. This specifies the amount of time the valve should be ON and OFF during the UP or load lifting operation.

- i. Use the “▲▼” buttons to select "SET VALVE TIMING" from "MENU MODE", then press the “ENTER” button (Refer to screen 2).
- ii. Use the “▲▼” buttons to select the valve ON and OFF time duration for the UP and DOWN operations (Refer to screen I.1).

NOTE: When entering the time duration, the system will not allow you to put zeros in all places. The minimum value is 30 MS.

- iii. Select the option "UP ON" by pressing the "ENTER" button. Then add the required time duration for the UP operation using buttons “▲▼” and “◀▶” (Refer to screen I.2).
- iv. Repeat the above steps to set the time duration for "UP OFF", "DOWN ON" and "DOWN OFF".

NOTE: It is suggested that for the first run, the duration "ON" and "OFF" be set at 60 ms.

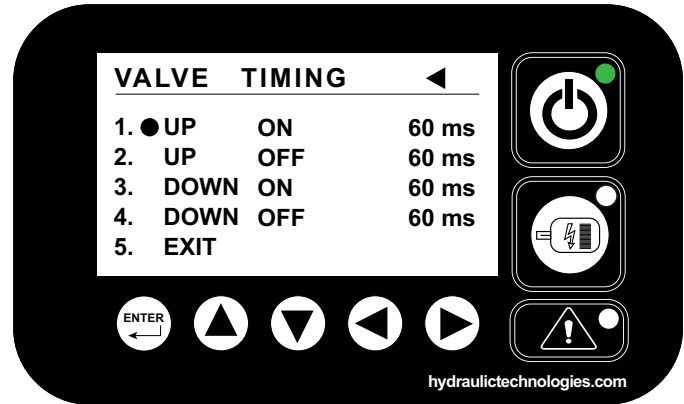

Screen I.1

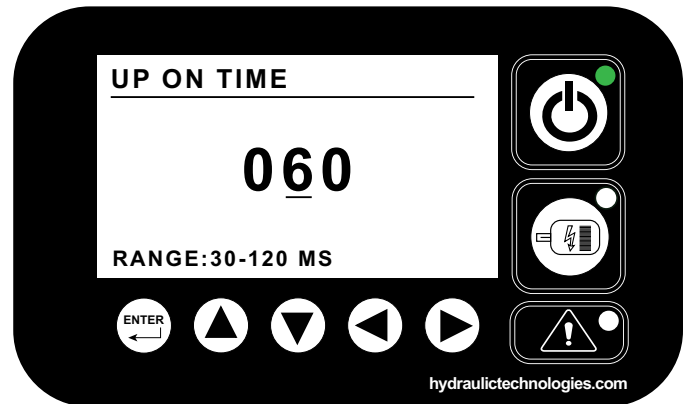

Screen I.2

LCD Screen Functions Continued

J. SET SENSOR MAX

The sensor is designed to measure linear displacement within a range of up to 1000 mm or 39.37 inches. This range allows the sensor to accurately monitor the movement of the lifting cylinders as the load is raised to the desired height in the lifting operation.

- Use the “▲▼” buttons to select "SET SENSOR MAX" from "MENU MODE", then press the “ENTER” button (Refer to screen 2).
- Use the “▲▼” buttons to select the required sensor or all sensors, then press the “ENTER” button (Refer to screen J.1).
- Use the “▲▼” and “◀▶” buttons to enter a desired distance value, then press the “ENTER” button to save the value (Refer to screen J.2).

E.g., all sensors are chosen and configured to set 39.37 inches as the maximum allowable distance.

NOTE: You can replace the displacement sensors with any type that provides 4-20 mAmp output. If replaced, be sure to enter the correct numbers for the particular sensor.

K. LCD BACKLIGHT

The LCD backlight allows users to customize the brightness level of the display according to their preferences. This improves the visibility of the information displayed on the screen.

- Use the “▲▼” buttons to select "LCD BACKLIGHT" from "MENU MODE", then press the “ENTER” button (Refer to screen 3).
- Use the “▲▼” buttons to select the brightness level, then press the “ENTER” button (Refer to screen K.1).

L. LCD HEATER

The LCD heater is used to maintain the temperature of the LCD screen above the dew point to prevent moisture buildup that can affect visibility and readability. It helps to ensure that the display remains clear and operational even in cold or humid environments.

- Use the “▲▼” buttons to select "LCD HEATER" from "MENU MODE", then press the “ENTER” button (Refer to screen 3).
- Use the “▲▼” buttons to select the required heater level, then press the “ENTER” button (Refer to screen L.1).

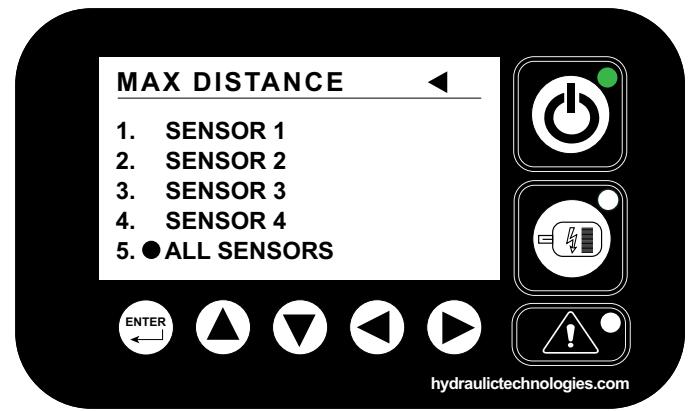

Screen J.1

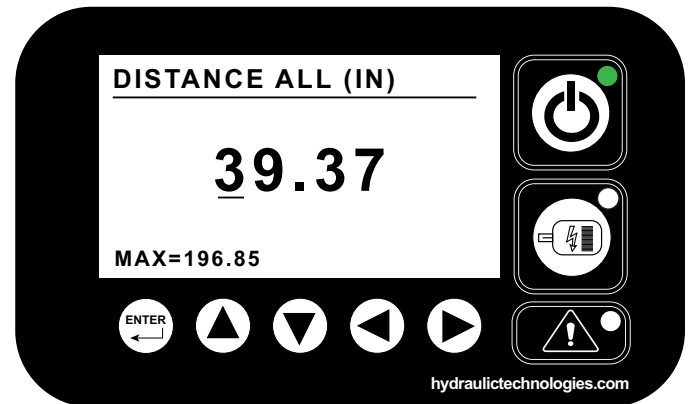

Screen J.2

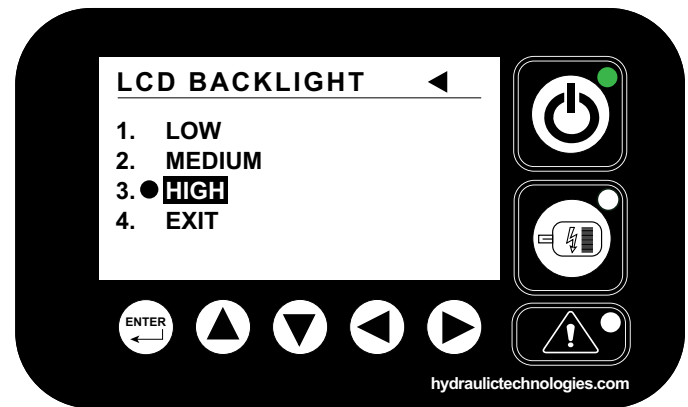

Screen K.1

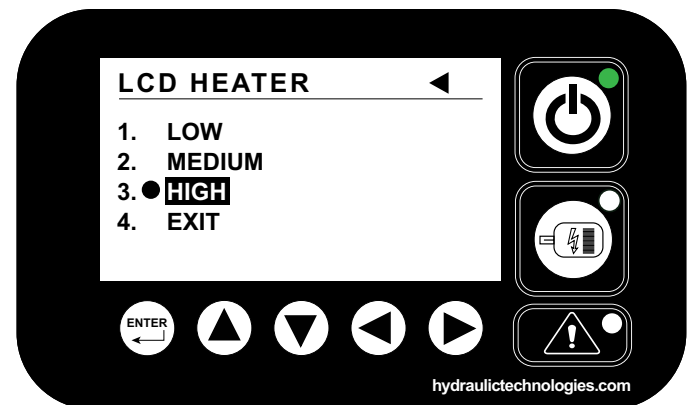

Screen L.1

LCD Screen Functions Continued

M. UNITS

This allows the user to select different units in the system.

- i. Use the “▲▼” buttons to select "UNITS" from "MENU MODE", then press the “ENTER” button (Refer to screen 3).
- ii. Use the “▲▼” buttons to select the metric system "MM/BAR" or imperial "IN/PSI" based on requirement, then press the “ENTER” button (Refer to screen M.1).

NOTE: All parameters will be displayed based on the unit type selected.

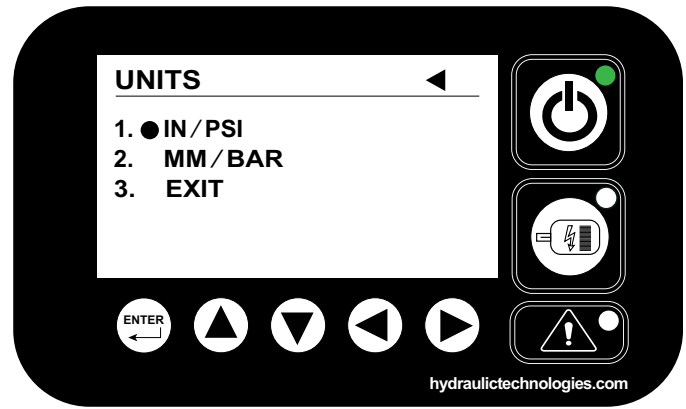

Screen M.1

N. FACTORY

NOTE: The factory reset option is not permitted for the user access and is password protected. For any troubleshooting needs, please contact the authorized service centers of Power Team.

The factory reset option is used to restore the system settings to their original factory configurations. This feature is typically utilized to troubleshoot issues or revert back to default settings (Maximum pressure and Pump ON time) if customized configurations are causing malfunctions. If a user chooses to replace a pressure transducer with one that has different settings, manually overwriting those settings is not recommended.

Performing a factory reset will erase all user-defined settings and return the system to its default state. It is important to note that a factory reset will delete any saved data and configurations.

O. EXIT

The EXIT button is used to navigate back or exit from the current screen or mode in a system.

ESYNC OPERATION

1. Before Operation

Before starting the eSync operation, check the following points:

- A. Verify that all hydraulic cylinders, hydraulic hoses and position sensors are correctly positioned and connected according to the set-up instructions.
- B. Make sure that the pump unit or fluid supply system is properly connected to the eSync unit (Refer to pump and eSync set-up instructions).
- C. Check that the hand pendant is connected to the eSync unit, ensuring that no buttons are pressed.
- D. Set the all necessary working parameters on the LCD screen referring to the LCD instructions for the lifting or lowering operation.
- E. Connect the eSync power cord to a suitable power source for the electric eSync unit, or insert a battery into the battery-operated eSync unit.
- F. Once everything is setup and configured, follow below instructions for Hand Pendant operation, Manual and Auto Operation based on requirements.

2. Hand Pendant Operation

NOTE: Before powering on, make sure that all pendant buttons are in their default unpressed position. If any pendant button is pressed when the power is turned on, the motor may not turn on.

- A. Button 1: Depress and release the "AUTO STOP" button to stop AUTO mode operation.
- B. Button 2: Depress and release the "MANUAL/AUTO" button to switch modes from MANUAL to AUTO or vice versa.

NOTE: The function is maintained once button 1 is depressed and cannot run simultaneously with buttons 2, 3, and 4. Similarly, if button 2 is depressed, it cannot run simultaneously with buttons 1, 3, and 4.

- C. Button 3 in MANUAL mode: Depress and hold the "ADVANCE" button to initiate solenoid advance and lift the load. Once released it will stop the advance operation.

Button 3 in AUTO mode: Depress and release the "ADVANCE" button to initiate solenoid advance and lift the load. Depress the "AUTO STOP" button to stop "AUTO" mode.

- D. Button 4 in MANUAL mode: Depress and hold the "RETRACT" button to initiate solenoid retract and lower the load. Once released it will stop the retract operation.

Button 4 in AUTO mode: Depress and release the "RETRACT" button to initiate solenoid retract and lower the load. Depress the "AUTO STOP" button to stop "AUTO" mode.

NOTE: In manual mode, the Deadman switch function is active, and in "AUTO" mode, the function remains active once depressed. Button 3 cannot be activated simultaneously with buttons 1, 2, and 4. Similarly, button 4 cannot be activated simultaneously with buttons 1, 2, and 3.

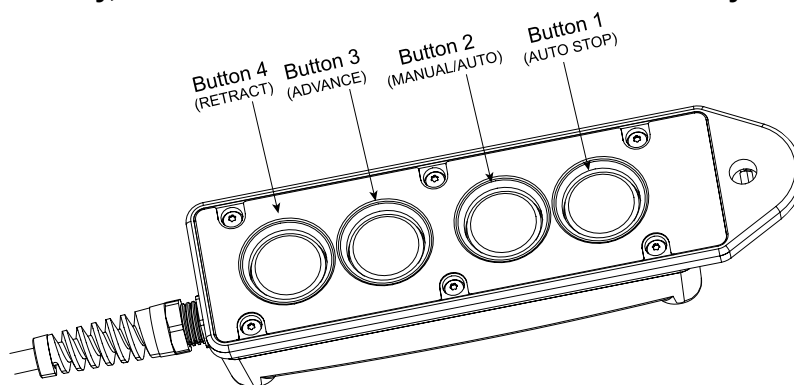

Fig. 18: Four Button Hand Pendant Control

3. Manual Operation

Manual Mode is used to make small positioning movements in the application. In manual mode users can independently adjust the lifting position of each lifting point using manual controls. This mode allows for precise adjustments and monitoring of each lifting point.

WARNING

- In manual mode, there is no synchronization. Loads will need to be monitored more closely to ensure they are lifted or lowered in a safe manner.
- There is NO control over the actual movement of the load in manual mode! Set the maximum pressure to a setting that allows the plunger of each cylinder to move. However, this pressure setting must be low enough such that the cylinder cannot move the load but only makes firm contact with the load to be lifted. During this operation, the plunger of each cylinder will come into contact with the lifting point of the load. This can cause a pinch point. Make sure all personnel stand clear of moving plungers.

IMPORTANT: Too high of a pressure setting can cause a cylinder to start moving the load and cause unduly stress or even damage to the structure to be moved. Activate each circuit one by one until the plunger is in full contact with the load and the pre-set max pressure has been reached.

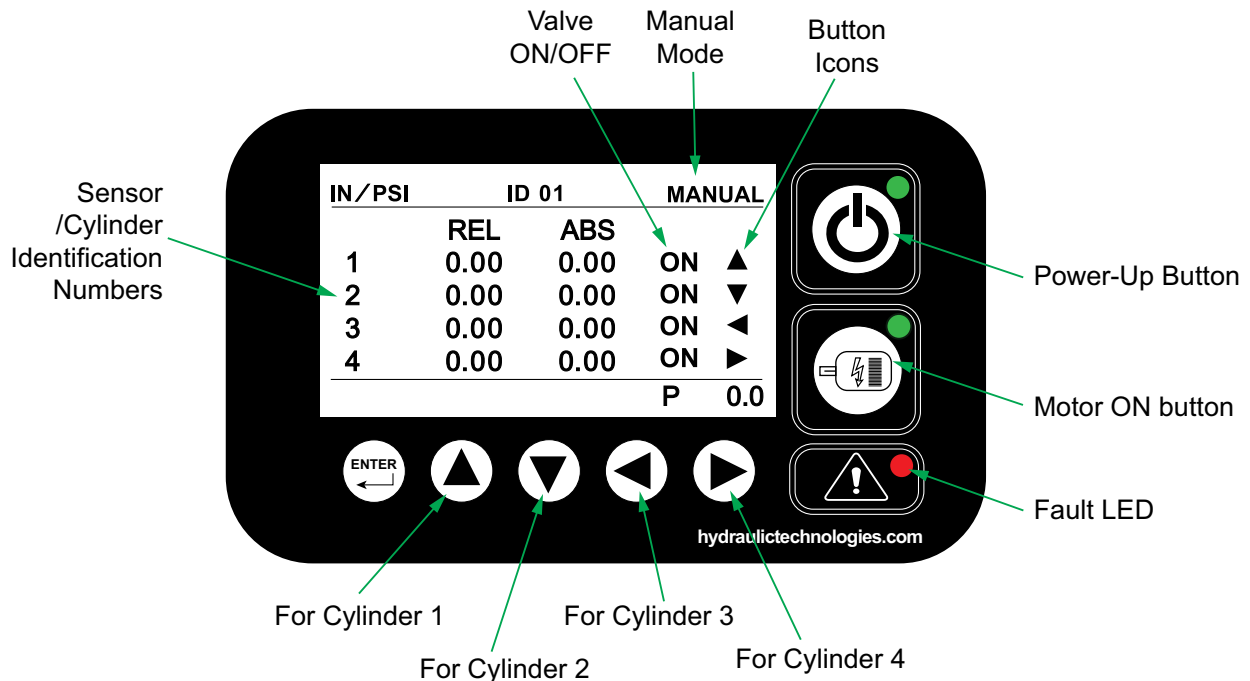

To Perform a Manual Operation:

- Press the POWER UP button on the eSync LCD panel to activate the eSync unit.
- During power up the system performs a system check to verify if any button(s) are depressed or activated on the display or pendant. If any faults are detected, a red fault light will illuminate. Review the errors, and after verifying them, restart the system to enable it to perform another system check.
- If no errors found set the TIME and DATE on the next screens (Refer to section "LCD Startup Splash Screen").

eSync Operation Continued

- D. Set the following necessary working parameters for the Manual operation referring to the LCD instructions:
- i. UNITS
 - ii. SET SENSOR MAX
 - iii. SET TIMEOUT
 - iv. SET VALVE TIMING
- E. After setting all parameters, navigate to the output screen (refer to the screen above) to confirm the input values.
- F. Ensure that manual mode is selected. If not, depress the "MANUAL/AUTO" button on the hand pendant to switch to manual mode.
- G. To enable particular valve or cylinder operation, use the "▲▼" and "◀▶" buttons to switch the valve position to ON/OFF for cylinders 1 through 4, enabling you to select the cylinders needed for the operation (see screen above).
- H. On the hand pendant depress and hold the "ADVANCE" button, cylinder plunger will move upward displaying absolute and relative readings on the screen. Release ADVANCE button once the desired value is reached.
- I. Depress and hold the "RETRACT" button on the hand pendant. The cylinder plunger will move downward until the button is released.
- J. This movement should be performed intermittently raising the cylinder piston rod 1 or 2 inches at a time until it gently touches the load to be lifted.

NOTES:

- **While in Manual operation mode only one cylinder may be operated at a time. System pressure should be low enough, there will be cylinder movement, but not high enough to allow the load to be lifted.**
- **Depending upon the length of hoses and the size of the cylinder's used as well as the length of the initial stroke it may be necessary to add additional oil to the tank.**
- **In any circumstance it is recommended to use pre filled hydraulic hoses with the same oil as the rest of the system before any lift is performed.**

eSync Operation Continued

4. Auto Operation

Auto Mode helps to automate the process of lifting or lowering a load in a synchronized manner. In this mode, operators can set specific parameters such as the target lifting height and tolerance levels through the menu interface. The system will then automatically control the movement of all cylinders, adjusting their speed and position to ensure synchronized lifting or lowering of the load.

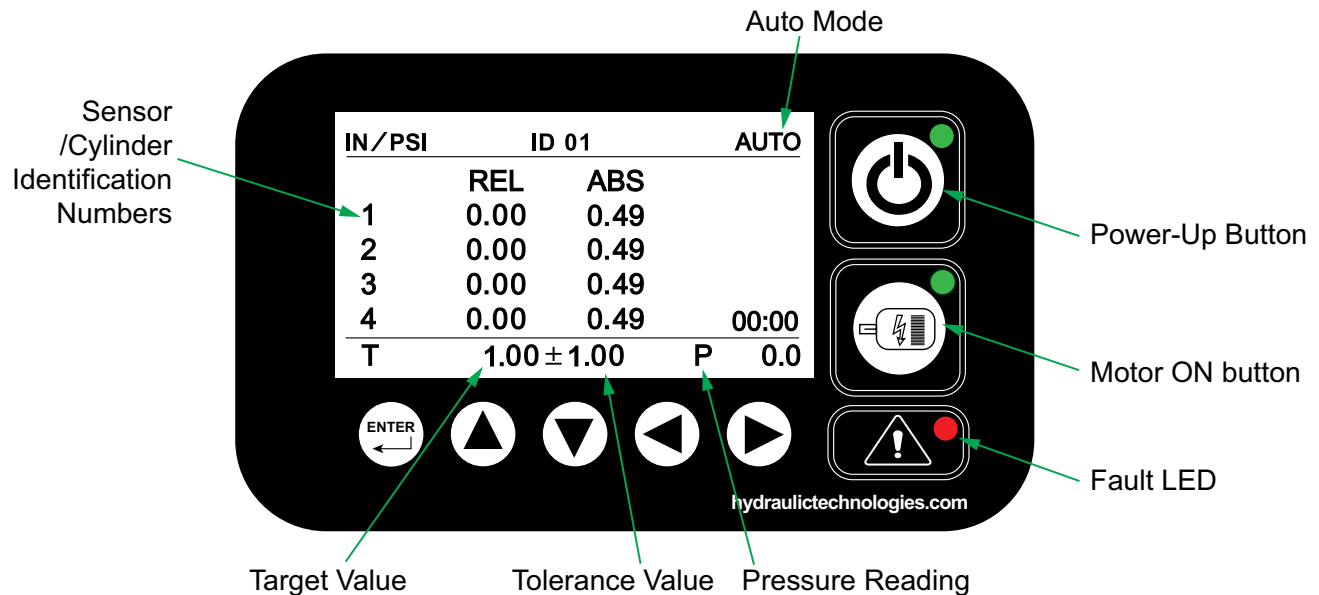

To Perform a Auto Operation:

- A. Before carrying out the auto lift or lower operation, preload all cylinders for the application using manual mode. Make sure that all cylinders make gentle contact with the load being lifted.
- B. Set the following necessary working parameters for the Auto operation referring to the LCD instructions:
 - i. UNITS
 - ii. SET SENSOR MAX
 - iii. SET ZERO ABSOLUTE
 - iv. SET ZERO RELATIVE
 - v. SET TARGET
 - vi. SET TOLERANCE
 - vii. SET TIMEOUT
 - viii. SET VALVE ENABLE
 - ix. SET VALVE TIMING
 - x. LINK SETUP (Use this option when connecting multiple remote eSync units)
- C. After setting all parameters, navigate to the output screen (refer to the screen above) to confirm the input values.
- D. Ensure that auto mode is selected. If not, depress the "MANUAL/AUTO" button on the hand pendant to switch to auto mode.
- E. Depress and release the "ADVANCE" button on the hand pendant to lift the load to a preset TARGET value. Once the target is achieved, the load lifting will automatically stop, and the user can see the target value on the screen.
- F. Depress and release the "RETRACT" button on the hand pendant to lower the load to a preset target value.
- G. When all cylinders reach the desired position, the system automatically stops the operation.
- H. Use the "AUTO STOP" button on the hand pendant to stop "AUTO" operation at any time.

5. Load Lowering Valve Operation

- These valves are designed to regulate the flow of hydraulic fluid returning from the cylinders as the load is lowered, preventing sudden drops or uncontrolled movements.
- The load lowering valve (a restrictive style control that has free-flow in one direction and controlled flow in the other). It is used to control the rate of descent in lowering the load. Rotating clockwise will decrease the flow rate, resulting in slower speeds, while rotating counter-clockwise will increase the flow rate for faster speeds.
- Close the valve completely, then reopen one 16th to one 8th turn. This should be used as a baseline from which to observe lowering performance. If lowering speed is too slow, open the adjustments by turning the handle counter-clockwise in one 16th turn increments.

WARNING : Not closing the load lowering valve properly can result in the load moving at a speed higher than anticipated, creating an unstable situation that could potentially lead to the loss of the load or personal injury.

NOTE: The load-lowering valve has a built-in internal relief valve. If the relief valve pressure is ever reached, hydraulic oil will spill out of a weep hole that is located on the side of the lowering valve body.

- It is normal to have some seepage of oil from the weep hole due to a shifting load and/or thermal expansion, however, if there appears to be a steady flow of oil seeping from the weep hole, stop the eSync unit and contact Power Team Technical Support at +1 800-477-8326.

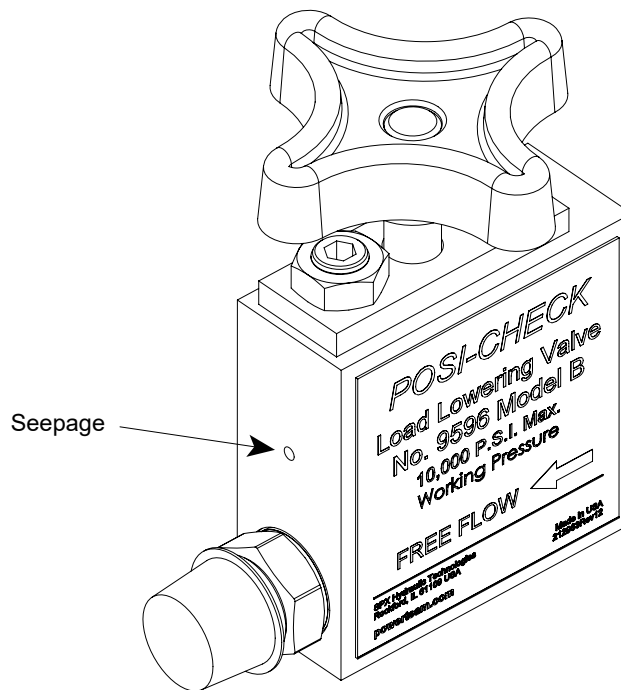

Fig. 19: Load Lowering Valve

CAUTION : If the operator adjusts the load-lowering valve to decrease the flow rate, it can potentially create a restriction that raises the pressure in the cylinder above the maximum system rating. It is essential to monitor the pressure while lowering the load. If the pressure starts nearing the maximum limit of 700 bar (10,000 psi), pause the movement and lower the retract pressure by adjusting the retract pressure relief valve to a lower value like 100 bar (1500 psi) until the pressure in the advancing line drops to a safe level.

PUMP OPERATION

The following instructions provide the operation guidelines for the Power Team electric and battery-powered pump versions used with the eSync units.

⚠ WARNING : It is recommended to use Power Team Pumps and Vales that supports fluid supply system for the eSync unit. If you prefer to use a different pumps or fluid supply system, please reach out to Power Team technical support for appropriate guidance.

1. Before Operation

Before starting the operation, check the following points:

- Ensure that the eSync unit is fully set-up according to the eSync set-up instructions, which include hydraulic connections, electrical connections, and the installation of the cylinders and sensors.
- Confirm that the pump unit is fully set-up in accordance with the pump set-up instructions, which detail how to connect the PE60 pump and PB43 pump to the eSync unit.
- Make sure you are using the electric version pump unit with the electric version of eSync unit and the battery version pump with the battery powered eSync unit.

2. Priming the Pump

When operating the pump for the first time

- A. Valve and hose connections must be tight, and the reservoir must be filled to the proper oil level.
- B. Jog the pump several times to build pressure. If the pump doesn't build pressure, it may not be primed. Disconnect a hose from the system and route it back to the pump reservoir. Run the pump until a steady flow of oil is observed free of suspended air bubbles. Reconnect the hose to the system.
- C. Run the tool several times to eliminate air from the system. For more complete instructions, refer to the section titled "Bleeding Air from the System."
- D. The pump is now ready to be put into regular operation.

IMPORTANT: After eliminating trapped air from the system, retract the tool and refill the pump reservoir to 1" (25,4 mm) from the bottom of the cover plate or to fill line.

3. Electric Pump (PE60) Operation

⚠ WARNING : Before connecting and operating the pump unit, ensure that all hydraulic connections between Pump and eSync units are properly established.

- A. Ensure that the pump power cord and the pressure/return lines are securely connected to the eSync unit before activate pump unit (refer set-up instructions).
- B. To activate the pump unit, press the ON/OFF push button (see figure 11) to the ON position (green light illuminates); this will activate the pump unit.
- C. Once the pump unit is set up, refer to the hand pendant and eSync unit operation guidelines for lifting and lowering the load.
- D. After completing the work, press the ON/OFF push button to the OFF position to deactivate the pump unit.

Pump Operation Continued

4. Battery Pump (PB43) Operation

⚠ WARNING: Please adhere to the specified Battery Operating Temperature range of -4°F to 104°F (-20°C to 40°C) and the Battery Charging Temperature range of 41°F to 104°F (5°C to 40°C). Operating or charging the battery outside of these specified temperatures may cause damage to the battery and increase the risk of fire.

- A. Make sure the battery pack is fully charged and inserted properly into the pump power head.
- B. Ensure that the pump tether cable and the pressure/return lines are securely connected to the eSync unit before activate pump unit (refer set-up instructions).
- C. To activate the pump unit, press the ON/OFF push button (see figure 13) to the ON position (green light illuminates); this will activate the pump unit.
- D. Once the pump unit is set up, refer to the hand pendant and eSync unit operation guidelines for lifting and lowering the load.
- E. After completing the work, press the ON/OFF push button to the OFF position to deactivate the pump unit.

⚠ WARNING: Remove the battery pack from the both units when it is not in use. Leaving the battery installed for an extended period of time can lead to complete drainage, which may cause battery failure and damage the equipment.

5. Adjusting the Pressure Regulating Valve

The pressure regulating valve can be adjusted to bypass fluid at a given setting while the pump continues to run (see figure 20).

User Adjustable Relief Valve:

NOTE: For easy adjustment of the pressure regulating valve, always adjust the pressure by increasing to the desired pressure setting.

- A. Loosen the locknut on the pressure regulating valve, and back the adjusting screw or knob out a few turns by turning it in a counterclockwise (CCW) direction. This will decrease the setting to a lower than desired pressure.
- B. The pump must be completely connected electrically and hydraulically. Start the pump and build pressure.
- C. Slowly turn the adjusting screw or knob in a clockwise (CW) direction. This gradually increases the pressure setting. When the desired pressure is reached, cycle the pump again to verify correct pressure setting. Once set, lock the adjusting screw in position by tightening the locknut. Shut off the pump.

IMPORTANT: The pressure range is from 1,000 to 10,000 PSI (70 to 700 BAR) depending on the pump model.

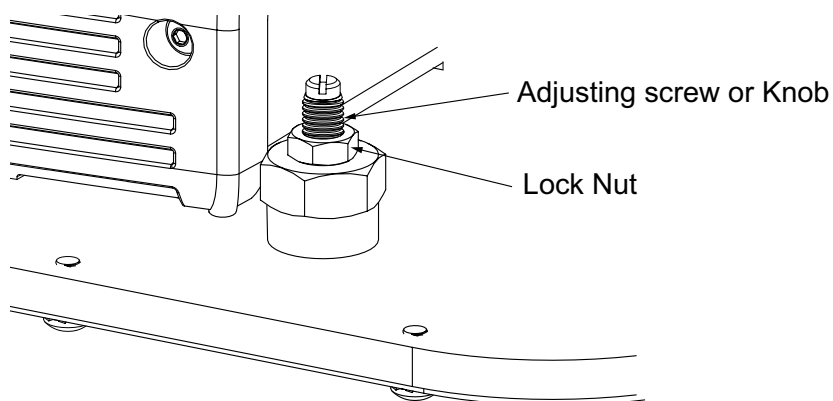

Fig. 20. Pressure Regulator Valve

GENERAL MAINTENANCE

⚠ WARNING : To prevent personal injury,



- Disconnect the unit from the power supply or remove the battery pack before performing maintenance or repair procedures.
- Repairs and maintenance are to be performed in a dust-free area by a qualified technician.

1. System Evaluation

The components of your hydraulic system — pump, hoses, and couplings — all must be:

- Rated for the same maximum operating pressure.
- Correctly connected.
- Compatible with the hydraulic fluid used.

A system that does not meet these requirements can fail, possibly resulting in serious injury. If you are in doubt about the components of your hydraulic system, contact Power Team Technical Support.

2. Inspection

Keep a dated and signed inspection record of the equipment. Before each use, the operator or other designated personnel should visually inspect for the following conditions:

- Excessive wear, bending, damage, or insufficient thread engagement.
- Leaking hydraulic fluid.
- Loose fasteners, pipe plugs, or fittings.
- Bent or damaged couplers or port threads.

3. Periodic Cleaning

⚠ WARNING : Contamination of the hydraulic fluid could cause the valve to malfunction.

- Establish a routine to keep the hydraulic system as free from debris as possible.
- Seal unused couplers with protective covers.
- Keep hose connections free of debris.
- Keep the breather hole in the filler cap clean and unobstructed.
- Use only Power Team hydraulic fluid. Replace hydraulic fluid as recommended, or sooner if the fluid becomes contaminated. Never exceed 300 hours of use between fluid changes.

4. Hydraulic Fluid Level

- A. Check the fluid level in the reservoir after each 10 hours of use. The fluid level should be 1" (25,4 mm) from the bottom of the cover plate or to the fill line when all cylinders or tools are retracted.
- B. Drain, flush, and refill the reservoir with an approved Power Team hydraulic fluid after 300 hours of use. The frequency of fluid changes depends on general working conditions, the severity of use, and the overall cleanliness and care given to the pump. Fluids should be changed more frequently when the system is used outdoors or in a dirty environment.

General Maintenance Continued

5. Draining and Flushing the Reservoir

- A. Disconnect the power supply or remove battery pack.
- B. Clean the pump exterior before the pump interior is removed from the reservoir.
- C. Remove all screws fastening the motor and pump assembly to the reservoir.
- D. Remove the motor assembly and place aside.

CAUTION: Do not damage the pump filter or pressure regulating valves when lifting the pump and motor off the reservoir.

- E. Clean the inside of the reservoir, and fill with Power Team hydraulic fluid. Rinse the filter clean.
- F. Place the pump and motor assembly back onto the reservoir, and secure with two fasteners assembled on opposite corners of the cover plate.
- G. Place the hydraulic flow control valve in the neutral position. If the pump is equipped with a valve that has only an advance or retract position, place the valve in the advance position, and connect a hose to the advance port on the valve. Place the other end of the hose into the fluid filler plug hole.
- H. Run the pump for several minutes.
- I. Disconnect the motor and pump assembly, and drain and clean the inside of the reservoir.
- J. Fill the reservoir with Power Team hydraulic fluid.
- K. Place the pump and motor assembly back onto the reservoir, and secure with fasteners. Tighten screws securely and evenly.

6. Adding Hydraulic Fluid to the Reservoir

- A. Disconnect the power supply or remove battery pack.
- B. Make sure that all hydraulic actuators that may still be connected to the pump are in their fully retracted position.
- C. Clean the entire area around the filler cap.
- D. Remove the filler cap, and install a clean funnel with a filter.

NOTE: Use only Power Team hydraulic fluid 47 cSt @ 38°C (215 SUS @ 100°F). If low temperature requirements are needed, use hydraulic fluid 5.1 cSt @ 100°C (451 cSt @ -40°C).

- E. Fill the reservoir with hydraulic fluid to 1" (25,4 mm) from the bottom of the cover plate or to fill line.
- F. Install the filler cap. Verify the breather-hole is open, if applicable.

7. Hose Connections

CAUTION : To prevent personal injury from leaking hydraulic fluid, seal all hydraulic connections with a high-quality, non-hardening pipe thread sealant.



IMPORTANT : Pipe thread sealant tape can be used to seal hydraulic connections if only one layer of tape is used. Apply tape carefully, two threads back, to prevent it from being pinched by the coupler and broken off inside the system. Loose pieces of tape could travel through the system and obstruct the flow of fluid or cause interference of precision-fit parts.

General Maintenance Continued

8. Storage

- The original shipping crate is a convenient storage container for the eSync unit. Prior to placing the eSync back into the shipping crate, replace all dust covers on each lift point quick disconnect. Place each of the position sensors in one of the two plastic cases. Place each sensor cable in one of the cloth bags provided, and pack each of the bags into the large storage case. Remove oil from the pump reservoir.
- Cylinder and hoses should be stored/maintained separately.
- Store the eSync unit in a dry, well-protected area where it will not be exposed to corrosive vapors, dust, or other harmful elements. If the eSync unit has been stored for an extended period of time, it must be thoroughly inspected before it is used.
- **Battery Storage: For Lithium-ion battery pack storage longer than 30 days:**
 - i. Protect the battery against temperatures above 45°C. Protect the battery against heat and fire.
 - ii. Store the Lithium-ion battery pack where the Optimum Storage Temperature 50°F ~ 80°F (10°C ~ 26°C) and free of moisture.
 - iii. Store Lithium-ion battery packs in a 30%-50% charged condition. Every six months of storage fully charge the Lithium-ion battery pack. Exterior may be cleaned with a cloth or soft non-metallic brush.

NOTE: This battery pack has equipped with an advanced self-maintenance function. It can maintain 30% of its charge capacity automatically after it is stored over one month.

9. Checking Brushes on Universal Motors

To help prevent premature failure of the armature, check the brushes periodically:

- A. Disconnect the power supply.
- B. Remove shrouds, brush holder caps, and brush assemblies.
- C. The brush assemblies must be replaced if they are 6.5 mm (1/4") long or less (see figure 21).
- D. Install brush assemblies, brush holder caps.
- E. Clean/replace open cell foam behind shroud vents before re-installing shrouds.

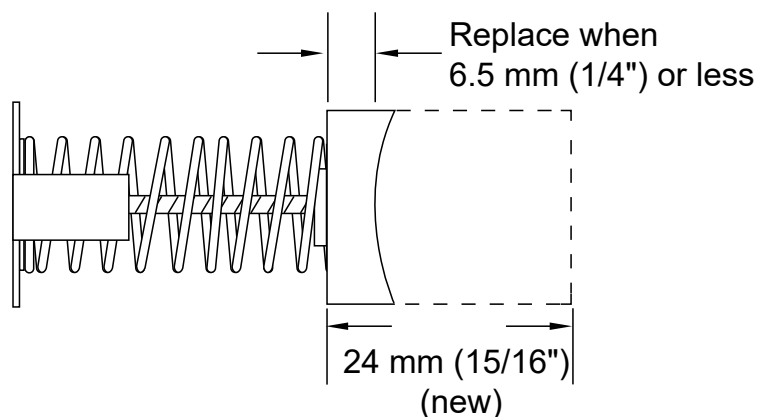

Fig. 21.
Brush Inspection

LCD FAULT MODE GUIDE

⚠ WARNING : Disconnect power source before service.

Fault Mode	Cause/Detection Method	Effect	User action
Keypad Button Down	During startup, the system checks to see if any buttons on the LCD keypad are depressed or active.	The red fault light turns on, and the LCD displays an error message, " KEYPAD BUTTON DOWN " which then stops the operation.	On the LCD, check for any pressed or damaged keypad buttons. Once completed, power up the system so that the device can perform another system check.
Pendant Button Down	During startup, the system checks to see if any button(s) on the pendant are depressed or active.	The red fault light turns on, and the LCD displays an error message, " PENDANT BUTTON DOWN " which then stops the operation.	Check for any depressed or damaged buttons on the hand pendant. Once completed, power up the system so that the device can perform another system check.
Multi Key Pressed	Multiple pendant keys have been long-pressed during operation.	The red fault light turns on, and the LCD displays an error message, " MULTI KEY PRESS " which then stops the operation.	Press the ENTER button to clear the error message from the system.
Pressure Sensor	Invalid (Low) pressure detected during startup.	The red fault light turns on, and the LCD displays an error message, " PRESSURE SENSOR " which then stops the operation.	Check the correct pressure value. Once completed, power up the system to clear the error message and restart it.
	The micro unit is not receiving the signal from the pressure transducer.	The red fault light turns on, and the LCD displays an error message, " PRESSURE SENSOR " which then stops the operation.	Visually inspect the pressure transducer and cable. Once completed, power up the system to clear the error message and restart it.
Logging Fault	Error occurs when attempting to enter lift data into the log during lift operation.	The red fault light turns on, and the LCD displays an error message, " LOGGING FAULT " which then stops the operation.	Press the ENTER button to clear the error message from the system.
Configuration Error	Error occurs when attempting to access configuration memory during startup.	The red fault light turns on, and the LCD displays an error message, " EEPROM-CONFIG " which then stops the operation.	Press the POWER button to clear the error message from the system and restart it.
Control Fault	A runtime error detected indicating that the memory copy of the configuration data is corrupted.	The red fault light turns on, and the LCD displays an error message, " CONTROL FAULT " which then stops the operation.	Press the POWER button to clear the error message from the system and restart it.

LCD Fault Mode Guide Continued

Fault Mode	Cause/Detection Method	Effect	User action
USB Error	Error occurs when transferring log file to USB drive.	The red fault light turns on, and the LCD displays an error message, " USB WRITE ERROR " which then stops the operation.	Check the USB connection and press the ENTER button to clear the error message from the system.
Lift Timeout for Valve 1, Valve 2, Valve 3 and Valve 4.	Standalone mode: valve 1 timeout, valve 2 timeout, valve 3 timeout, and valve 4 timeout, respectively.	The red fault light turns on, and the LCD displays an error message, " LIFT TIMEOUT -V1 " which then stops the operation. Similarly for the V2, V3, and V4.	Check system parameters and reset the time if required, then press the ENTER button to fix the error.
Lift Timeout	The system has exceeded the predefined valve time limit for a lift operation.	The red fault light turns on, and the LCD displays an error message, "LIFT TIMEOUT" with node ID and valve number, which then stops the operation.	Check system parameters and reset the time if required, then press the ENTER button to fix the error.
Node Not Ready	During auto lift/down operation, the master unit checks the linked unit's on/off status.	The red fault light turns on, and the LCD displays an error message, " NODE NOT READY " with node ID, which then stops the operation.	Check that the link setup mode is in ON condition for the linked units, then press the ENTER button to fix the error.
Node Responded Nack	An internal error occurs when a linked node is unable to execute a requested operation during a linked lift.	The red fault light turns on, and the LCD displays an error message, " NODE RESPONDED NACK " with node ID, which then stops the operation.	Check that the link setup settings for the linked units, then press the ENTER button to fix the error.
Node No Response	Communication lost between linked units.	The red fault light turns on, and the LCD displays an error message, " NO RESPONSE " with node ID, which then stops the operation.	Check all settings and cable connections for the linked unit, then press the ENTER button to fix the error.
Tolerance Error	The difference in relative positions of sensors is greater than the set tolerance value.	The red fault light turns on, and the LCD displays an error message, " LIFT TOLERANCE " along with node ID and valve information, which then stops the operation.	Check the relative positions of the sensors. Reset the relative positions, then press the ENTER button to fix the error.

TROUBLESHOOTING GUIDE

⚠ WARNING

- To help prevent personal injury, any repair work or troubleshooting must be done by qualified personnel familiar with this equipment.
- Disconnect the unit from the power supply or remove battery pack before performing maintenance or repair procedures.
- Use the proper gauges and equipment when troubleshooting.
- Plug the outlet ports of the pump when checking for leakage to determine if the leakage is in the pump, in the cylinder, or in the tool/hose.
- It is best to check for system leaks by using a hand pump and applying pressure to the suspect area. Watch for leaking fluid and follow it back to its source. ***Never*** use your hand or other body parts to check for a possible leak.

NOTE: For a detailed parts list or to locate a Power Team Authorized Hydraulic Service Center, contact your nearest Power Team facility.

1. For eSync System

PROBLEM	CAUSE	SOLUTION
The eSync unit does not power up	Electric Version eSync	
	1. Unit is not plugged in.	1. Plug in the unit.
	2. No voltage supply.	2. Check line voltage.
	3. Circuit breaker tripped because the total amperage draw was too high for the existing circuit.	3. Use an alternate circuit with a sufficient power supply.
	4. Damaged power cord.	4. Repair or replace the power cord.
	5. Internal defects or systems need to be serviced.	5. Contact the Power Team authorized service center.
	Battery Version eSync	
	1. Battery failure	1. Charge or replace battery
	2. Battery not inserted properly.	2. Remove and reinsert battery.
	3. Pump and battery contacts damaged.	3. Reform contacts
4. Internal defects or systems need to be serviced.	4. Contact the Power Team authorized service center.	
The master unit does not detect any linked units	1. There is a loose connection between the linked units.	1. Verify that the cables are properly connected with the correct connectors.
	2. The Link Setup mode is not activated.	2. Ensure that the mode is activated for all linked units.
	3. The locked symbol is not visible on the output screen of the linked units.	3. Confirm that the linked units are set to AUTO mode and not to the UNLOCK/DISCOVER option.

Troubleshooting Guide Continued

PROBLEM	CAUSE	SOLUTION
The system is failing to maintain tolerance during automatic lifting and lowering operations.	1. The cylinder outlet port does not align with the displacement sensor port.	1. Ensure that the sensor port is connected to the corresponding cylinder. For example, Sensor cable 1 should be connected to cylinder 1.
Incorrect sensor output readings	1. Sensor calibration is outdated.	1. Check the calibration date and submit for calibration.
	2. Sensor cable connection error.	2. Ensure that all sensor cables are correctly connected.
	3. The sensor used was not rated correctly.	3. Make sure to use the appropriate sensor that offers a 4-20 mA output.
The operation does not start	1. Not in correct LCD screen.	1. Navigate to operation output screen.
	2. No operation has been chosen.	2. Choose the necessary operation mode.
	3. The cylinder valves are in the OFF position.	3. Activate the appropriate cylinder valves.
	4. Incorrect operation settings have been selected.	4. Verify that all parameters have been accurately selected and correct values have been entered.
	5. The cylinders have not been zeroed.	5. Reset all cylinders to zero.
	6. Hydraulic connection error.	6. Check all hydraulic connections between the pump, cylinders, and eSync unit.
Remote hand pendant not working properly	1. Defective electrical supply.	1. Check electrical connections.
	2. Defective circuit board.	2. Contact a Power Team Authorized Hydraulic Service Center.
	3. Remote control connection wire is disconnected.	3. Check electrical connections.

Troubleshooting Guide Continued

2. For Pump Unit (Both Electric and Battery Version)

PROBLEM	CAUSE	SOLUTION
Pump motor does not run.	Electric Version Pump	
	1. Pump not turned ON.	1. Press the ON/OFF button on pump unit to activate pump.
	2. Unit is not plugged in.	2. Plug in unit.
	3. No voltage supply.	3. Check line voltage.
	4. Worn brushes.	4. Replace brushes.
	5. Fuse broken.	5. Verify the fuse connection. If it is broken or damaged, replace it.
	6. Broken lead wire or defective power cord plug.	6. Contact a Power Team Authorized Hydraulic Service Center.
	Battery Version Pump	
	1. Battery failure	1. Charge or replace battery
	2. Power head or battery contacts dirty or corroded.	2. Clean contacts when dry with non-conducting material.
	3. Battery not inserted properly.	3. Remove and reinsert battery.
	4. Pump and battery contacts damaged.	4. Reform contacts
	5. Broken lead wire or defective internal wiring.	5. Contact a Power Team Authorized Hydraulic Service Center.
Pump motor will not shut off.	1. Defective motor controls.	1. Disconnect the unit from the power supply; contact a Power Team Service Center.
Electric motor stalls, surges, overheats, or will not start under load.	1. Low voltage.	1. Check the line voltage and electric motor information. Refer to the electric pump set-up instructions section.
Erratic action	1. Air in the system.	1. Check for leaks. Refer to the bleeding procedure.
	2. Internal leakage in attached components.	2. Refer to the manufacturer's information for the attached component.
	3. Attached components sticking or binding.	3. Refer to the manufacturer's information for the attached component.
	4. Malfunctioning valve.	4. Verify connections. Contact the authorized Power Team Service Center.

Troubleshooting Guide Continued

PROBLEM	CAUSE	SOLUTION
Pump delivers excess oil pressure.	1. Faulty pressure gauge.	1. Calibrate gauge.
	2. Relief valve not properly set.	2. Contact a Power Team Authorized Hydraulic Service Center.
Pump is not delivering fluid or delivers only enough fluid to advance cylinder(s) partially or erratically.	1. Fluid level too low.	1. Fill reservoir according to directions "Filling the Pump Reservoir" under "Set-up Instructions" section.
	2. Quick disconnect couplings are not completely coupled.	2. Check quick-disconnect couplings to cylinders to ensure that they are completely coupled. Occasionally couplers have to be replaced because the ball check does not stay open due to wear.
	3. Air in system.	3. Refer to the section titled "Bleeding Air from the System" under "Set-up Instructions" section.
	4. Cold fluid or fluid too heavy. (Hydraulic fluid is of a higher viscosity than necessary.)	4. Drain, flush, and refill reservoir using a lighter weight fluid. Refer to General Maintenance section.
	5. Reservoir capacity is too small for the size of cylinder(s) used.	5. Use smaller cylinder(s) or larger reservoir.
	6. Vacuum in reservoir.	6. Check for plugged vent in filler plug.
	7. Debris in pump or filter plugged.	7. Pump filter should be cleaned and, if necessary, pump should be dismantled and all parts inspected and cleaned.
	8. Fluid bypasses through the double-acting cylinder.	8. Remove cylinder; cap hoses. Check pump and valve for leaks.
Pump builds pressure but cannot maintain pressure.	1. External leaks.	1. Seal leaking pipe fittings with pipe sealant. Replace leaking pipes or hoses.
	2. Internal or external leakage on hydraulic cylinder.	2. Remove the cylinder from pump. If the pump builds and maintains full pressure, the cylinder is defective. Contact a Power Team Authorized Hydraulic Service Center.
	3. Leaking control valve or check valve	3. Contact a Power Team Authorized Hydraulic Service Center.

Troubleshooting Guide Continued

PROBLEM	CAUSE	SOLUTION
Pump will not build full pressure.	1. Faulty pressure gauge.	1. Calibrate or Replace gauge.
	2. Check for external leakage.	2. Seal faulty fittings with sealant. Replace leaking pipes or hoses.
	3. Improperly adjusted external pressure regulator setting.	3. Refer to "User Adjustable Relief Valve" information under section "Pressure Regulating Controls".
	4. Internal or external leakage on hydraulic cylinder.	4. Remove the cylinder from the pump. If the pump builds full pressure, the cylinder is defective. Contact a Power Team Authorized Hyd. Service Center.
	5. Inadequate power supply.	5. Refer to Pump Set-Up instructions to confirm and verify the appropriate voltage requirements.
	6. Leaking control valve or defective pump.	6. Contact a Power Team Authorized Hydraulic Service Center.
Cylinder(s) will not retract or extend.	1. Quick disconnect couplings are not completely coupled.	1. Check quick disconnect coupling to cylinders to ensure that they are completely coupled. Occasionally couplers have to be replaced because the ball check does not stay open due to wear.
	<p>⚠ DANGER</p> <p>A Double acting cylinder or ram must have both hoses and all couplers securely connected to both ports. If one of the two ports is restricted or becomes disconnected, pressure will build and the cylinder, hose or coupler can burst, possibly causing serious injury or death.</p>	
	2. Broken return spring in spring return cylinder or seals blown in double-acting cylinder.	2. Contact a Power Team Authorized Hydraulic Service Center.

Troubleshooting Guide Continued

3. For Battery Pack and Charger

PROBLEM	CAUSE	SOLUTION
The battery pack power reduced after more than one month of non-use.	1. The battery pack has automatically performed self-maintenance to extend its life.	1. Fully recharge the battery pack before use.
The 4-LED indicator shines green-1HZ when the battery pack is working.	1. Abnormal battery pack temperature	1. Check whether the temperature line is poor contact. Let the temperature drop to (rise to) the normal working temperature range (- 20°C ~ 40°C). Replace the main board.
The 4-LED indicator shines green-5HZ when the battery pack is working	1. Abnormal battery pack Li-ion cell.	1. Ensure that each section of the battery cell is connected properly. Make sure the voltage difference of each battery cell is within 1V. Ensure that the voltage of the lowest section of the battery cell is raised for 10 minutes of charging. Replace the main board or the battery cell.
Charger does not work. LED flashes red or the LED go out.	1. Battery pack or charger is defective or bad connection between the battery pack and charger.	1. Try to remove and reinsert the battery pack in the charger. Try charging a different battery pack. Unplug the charger and wait until the red LED goes out, then reconnect the plug to the power supply.
Charger does not work and LED shines red.	1. Battery pack is too hot or too cold.	1. Allow the battery pack to reach normal temperature. Charging will begin when battery pack returns to 37°F(3°C) -35°F(57°C).

HYDRAULIC SCHEMATIC

1. For Double Acting Cylinders

NOTE: The hydraulic schematic shows below is the integration of Power Team PE60 and PB43 pumps as the fluid supply system for the hydraulic circuit.

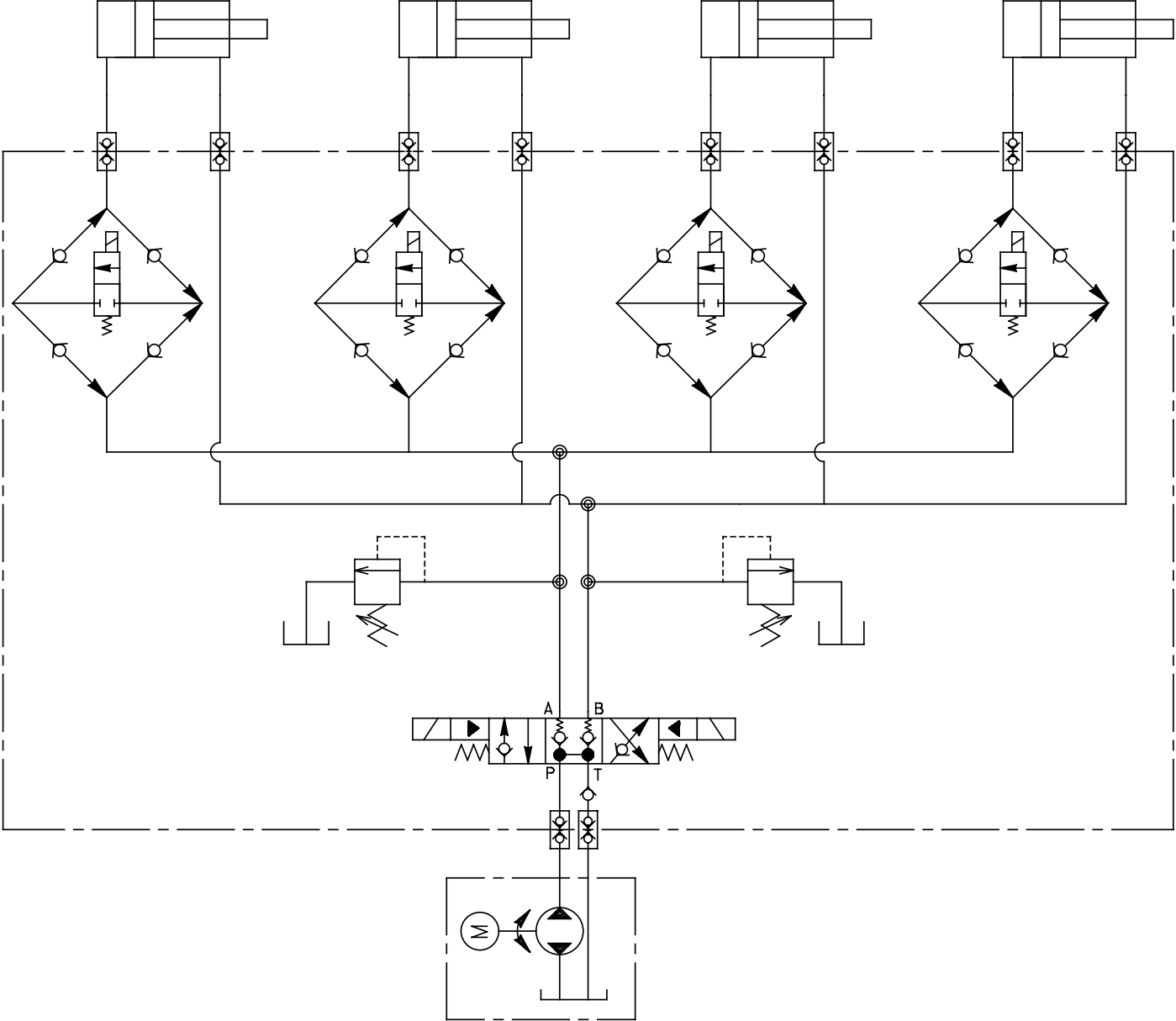

For questions regarding electrical and/or hydraulic schematics, contact Power Team Technical Support at 1-800-477-8326.

Hydraulic Schematic Continued

2. For Single Acting Cylinders

NOTE: The hydraulic schematic shows below is the integration of Power Team PE60 and PB43 pumps as the fluid supply system for the hydraulic circuit.

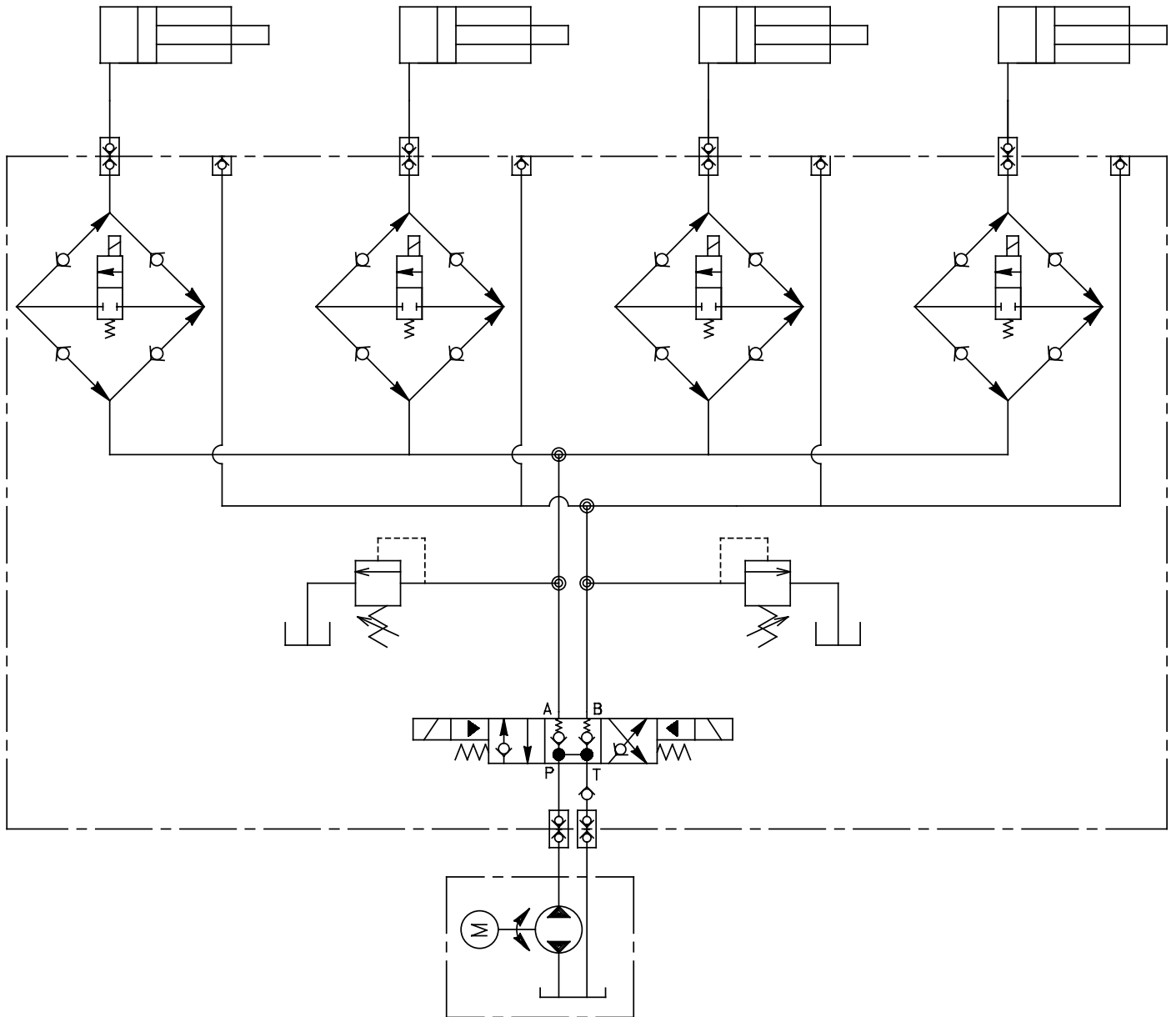

For questions regarding electrical and/or hydraulic schematics,
contact Power Team Technical Support at 1-800-477-8326.

COMPONENT SPECIFIC DATA SHEET

POSITION SENSORS

MEASUREMENT RANGE 0 MM TO 1000 MM (0 INCH TO 39.37 INCH)
ELECTRICAL CONNECTION. MALE, 5 PIN SOCKET MI2
OUTPUT CURRENT. 4 - 20 mAmp

PRESSURE TRANSDUCERS

PRESSURE RANGE 0 BAR TO 1000 BAR (0 PSI TO 15,000 PSI)
HYDRAULIC CONNECTION. 1/8" NPT
ELECTRICAL CONNECTION. PIGTAIL-SHIELDED CABLE WITH PVC JACKET
AND 24 AWG LEADS
OUTPUT CURRENT. 4 - 20 mAmp

BATTERY PACK

VOLTAGE (MAX) 60 VDC
CAPACITY 8.0 AH
WATTS (NOMINAL) 432 WH

BATTERY CHARGER

US VERSION CHARGER

AC INPUT 110-130 VOLTS / 4.8 AMPS
DC OUTPUT 60 VOLTS / 5.5 AMPS

EU VERSION CHARGER

AC INPUT 200-240 VOLTS / 1.9 AMPS
DC OUTPUT 60 VOLTS / 5.5 AMPS

ESYNC CORD CABLE (OUTLET)

US VERSION 115 VAC, 20 AMPS, 12 AWG
EU VERSION 230 VAC, 15 AMPS, 14 AWG

HYDRAULIC PUMPS

PE60 ELECTRICAL PUMP

US VERSION 115 VAC, 60HZ, 1 HP, 700 BAR (60 CU.IN/MIN)
EU VERSION 230 VAC, 50/60HZ, 1 HP, 700 BAR (60 CU.IN/MIN)

PB43 BATTERY PUMP

US VERSION 60 VDC, 8 AH, 700 BAR (43 CU. IN/MIN)
EU VERSION 60 VDC, 8 AH, 700 BAR (43 CU. IN/MIN)

POWER TEAM FACILITIES AND CONTACT

Rockford, Illinois USA
Customer Service/Order Entry
Tel: +1 800 541 1418
Fax: +1 800 288 7031
Info.powerteam@spxflow.com

European Headquarters
Tel: +31 45 567 8877
CS.EMEA@spxflow.com

Asia Pacific Headquarters
Tel: +65 6265 3343
FT.APAC.HT@spxflow.com

Technical Services
Tel: + 1 800 477 8326
Info.powerteam@spxflow.com

Shanghai, China
Tel: +86 21 2208 5888
FT.APAC.HT@spxflow.com

EC DECLARATION OF CONFORMITY

We declare under our sole responsibility that our Electric eSync models, defined under the following series or specific part number as:

eSync - Series

to which this declaration relates are in conformity with the following:

2006/42 EC - Per the provisions of the Machinery Safety Directive	
EN_ISO 12100	Safety of machinery, basic concepts, general principles for design, risk assessment and risk reduction
EN 4413	Hydraulic Fluid Power – general rules and safety requirements for systems and their components
2014/30 EU - Per the provisions of the EMC Directive	
EN_61000-4-2	Electromagnetic Discharge Immunity test
EN_61000-4-3	Radiated, Radio Frequency, Electromagnetic Field Immunity test
EN_61000-4-4	Electrical Fast Transient / Burst Immunity test
EN_61000-4-5	Surge immunity test
EN_61000-4-6	Immunity to Conducted Disturbances, Induced by Radio-Frequency Fields
EN_61000-4-11	Voltage Dip and Interrupt test
EN 55011	Industrial, Scientific and Medical (ISM) Radio Frequency Equipment-Electromagnetic Disturbance Characteristics-Limits and Methods of Measurement
2014/35 EU - Per the provisions of the Low Voltage Directive	
EN_60204-1	Safety of Machinery –Electrical equipment of machines – Part 1 General requirements
2006/66/EC - Per the provisions of the Battery Directive	
IEC 61960	Secondary Lithium Cells and Batteries for Portable Applications
2000/14 EC - Per the provisions of the Noise Emission in the Environment by Equipment for Use Outdoors Directive	
EN_3200L0014	Noise emission in the environment for use outdoors
ISO 3744	Sound Power Level Measurements measured sound power level on an equipment representative for this type: 89 dB(A) guaranteed sound power level for this equipment: 91 dB(A) or less
2011/65/EU - Per the provisions of the RoHS Directive	
	Restriction of the use of certain hazardous substances in electrical and electronic equipment

Hydraulic Technologies USA LLC

5885 11th Street
Rockford,
IL 61109-3699
United States of America

We hereby declare that the equipment specified hereon, conforms to the above quoted European Community Directive(s) and Standard(s) as per the currently valid revision.

Hydraulic Technologies is certified and registered to ISO 9001: 2015.

Hydraulic Technologies

Netherlands B.V.

Albert Thijsstraat 12
NL-6471 WX
Eygelshoven
The Netherlands

The Netherlands,



Neil Hughes, Operations Lead EMEA

