

GKS Lifting and Moving Solutions LLC



[www.gksweb.com](http://www.gksweb.com)

### SPARE PARTS FOR JACK TYPE U6

Valid from October 2014

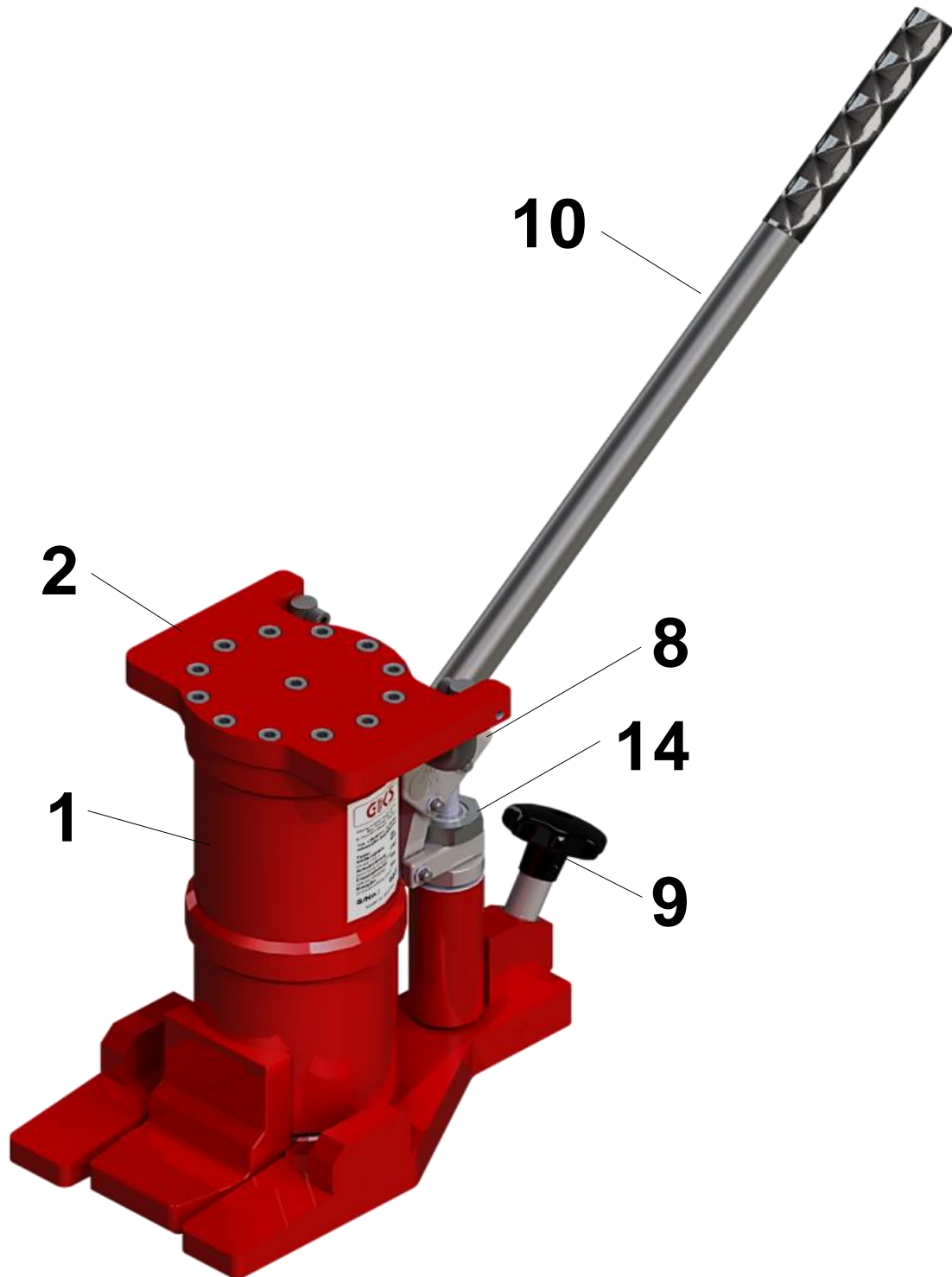

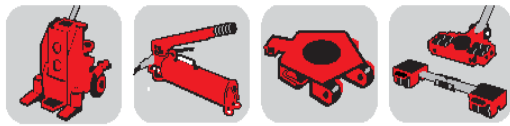

GKS Lifting and Moving Solutions LLC



www.gksweb.com

## SPARE PARTS FOR JACK TYPE U6

Valid from October 2014

POS.	DESCRIPTION		ART.-NO.	PRICE per pcs.
1	Slider		12802	X
2	Head Plate		13404	X
3	Guiding nut		12738	X
4	lifting piston complete		13408	X
5	Cylinder		12977	X
6	Thrust bolt complete		13409	X
7	Pump piston complete		12976	X
8	Plunger actuating block		10163	X
9	Drain screw complete		12744	X
10	Pump lever		10164	X
11	Valve complete		13280	X
12	Filter-double-ply		14928	X
13	O-Ring 17x1,6		14920	X
14	Screw Nut M20 x 1,5		12582	X
15	Seal kit U6 <span style="float: right;">14 St. / pcs.</span>		13383	X
	15.1	Button-type seal (1x)	10117	
	15.2	Washer 35x20x9 (1x)	10118	
	15.3	Guide Ring 80x85x14,7 (2x)	14905	
	15.4	Guide Band 3,8x1,5-0,062 (1x)	12108	
	15.5	O-Ring 18x2 (1x)	12578	
	15.6	O-Ring 14x2 (1x)	12579	
	15.7	O-Ring 29x3 (1x)	10111	
	15.8	Support Ring 18x21,3x0,7 (2x)	12592	
	15.9	O-Ring 10x3,5 (1x)	13302	
	15.10	O-Ring 20x2 (1x)	12590	
	15.11	O-Ring 42x3 (1x)	10267	
	15.12	O-Ring 66x3 (1x)	12591	
16	Copper-Ring 14x20x1,5		10115	X
17	Cu-Ring 11x20x1		10116	X

PLEASE USE ARTICLE-NO. WHEN ORDERING

Production revisions are subject to change.  
Prices are subjects to change without notice.

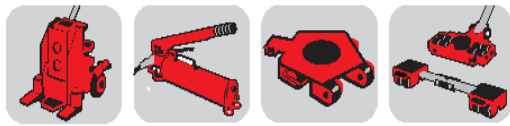

GKS Lifting and Moving Solutions LLC



[www.gksweb.com](http://www.gksweb.com)

### SPARE PARTS FOR JACK TYPE U6

Valid from October 2014

